

# [thecarversite.com](http://thecarversite.com)

This manual is either an original scan from tech's who worked at Carver corp, donated by forum members, or both. These manuals are NOT intended for re-sale. If you purchased a 'Carver Manuals' disc on ebay or another auction site, and it has this material on it, you were ripped off!

Please report any resale of this material to us at [thecarversite.com](http://thecarversite.com)

# [thecarversite.com](http://thecarversite.com)

[thecarversite.com](http://thecarversite.com)

# CARVER

## Model CT-6/PSC-60

### SERVICE MANUAL

#### CONTENTS

	Page
SAFETY INFORMATION .....	2
SPECIFICATIONS .....	2
ALIGNMENT PROCEDURES .....	4
VOLTAGE CONVERSION .....	6
BLOCK DIAGRAM .....	7
IC BLOCK DIAGRAM .....	9
PCB COMPONENT SIDE VIEWS .....	15
EXPLODED VIEWS .....	21
PARTS LIST .....	23
DIFFERENT PARTS LIST .....	27
SCHEMATIC DIAGRAMS .....	29

## SAFETY INFORMATION

### WARNING

Any person performing the procedures described in this manual will be exposed to hazardous voltages and the risk of electric shock.

Carver Corporation assumes that any person who removes the cover from the unit has been properly trained in protecting against avoidable injury and shock.

Therefore, the procedures described here are to be performed by qualified electronics service personnel only.

We recommend that the unit be tested only when line isolation is provided by an isolation transformer. The line cord of the unit must be disconnected and the power supply fully discharged before any components are replaced. Failure to do so may result in severe damage to the unit and the risk of electric shock.

The safety tests described in the CAUTION information located on the schematic diagram must be performed properly.

## SPECIFICATIONS

### Preamplifier Section

Frequency Response	Phono	RIAA $\pm 1$ dB
	Line level	20Hz-20kHz ( $\pm 0.5$ dB)
Input Impedance @ 1kHz	Phono	47k ohms
	Line level	30k ohms
Sensitivity for 1V RMS output	Phono	2.5mV ( $\pm 300\mu$ V)
	Line level	150mV ( $\pm 20$ mV)
Maximum input level 1kHz	Phono	120mV
	Line level	>8V
S/N ratio A weighted	Phono	80dB below 5mV input level
	Line level	95dB below 1V output level
	Hologram on	85dB below 1V output level
Maximum output level	Preamp out	6V RMS
	Tape out	6V RMS
	Headphone out	300mV with 8 ohm load 125mV with 8 ohm load
Headphone output level with 1V at pre out		
THD		.008% 20Hz-20kHz at 2V RMS out
Output impedance	Preamp out	680 ohms
	Tape out	1k ohms
	Headphone out	150 ohms
Minimum recommended load impedance	Preamp out	2.5k ohms
	Tape out	2.5k ohms
Gain Line level in to Tape out		-1dB
Channel balance @ max. volume		<2dB
Tone controls	Bass	$\pm 8$ dB at 100Hz ( $\pm 2$ dB)
	Treble	$\pm 8$ dB at 10kHz ( $\pm 2$ dB)
	Loudness	+5dB at 100Hz, +3dB at 10kHz
Mute effect		-20dB
Channel separation	1kHz	56dB
	10kHz	40dB
Sonic Hologram Generator image resolution		5 deg. horiz. 20 deg. vert.

## TUNER SECTION

### FM

IHF usable sensitivity		14.3dBf
Sensitivity for 50dB quieting	Mono	18.3dBf
	Stereo	37.3dBf
	ACCD	32.3dBf
Spurious response		>60dB
Image rejection		>40dB
IF rejection		>60dB
AM suppression		62dB
Capture Ratio		2.5dB
Alternate channel selectivity		72dB
Frequency response at 65 dBf input		10Hz-15kHz (+/-1dB)
THD at 65 dBf input 1kHz 100% mod.		0.15%
S/N Ratio at 65 dBf input		74dB
Stereo separation (65dBf 1KHz)		46dB

### AM

Sensitivity for 20dB quieting		500uV/m
Selectivity at 20dB S/N +/-10kHz		30dB
Spurious response		40dB
Image rejection		46dB
IF rejection		65dB
THD at 5mV/m 30% mod		1.2%

### GENERAL

Power Consumption		20W
Dimensions	Height	1.75" (45mm) not including feet
	Width	19" (480mm)
	Depth	12.75" (324mm) Chassis
		14.75" (375mm) overall
Weight		9 lbs. (4Kg)

## ALIGNMENT PROCEDURES

### Tuner (AM)

#### Condition

1. Modulation: 400 Hz, 30 %
2. TAPE OUT load: A 100 k $\Omega$  resistor shunted by a 1000 pF capacitor
3. Input level: 74 dB/m (5 mV/m) unless otherwise noted
4. Generator output: IRE loop antenna 24" (60cm) spacing or through IHF dummy (200 pF capacitor).
5. CH.STEP switch (SW301): US position (EX version only)
6. Preheat: More than 1 minute

#### TUNING VOLTAGE

1. Set the tuner frequency to 520 kHz.
2. No input.
3. Connect the DC digital volt meter to the test point TP1.
4. Adjust T4 until the voltage is  $1.00 \pm 0.05$  V.
5. Change the tuner frequency to 1710 kHz.
6. Adjust TC1 until the voltage is nearly 8 V.

#### IF

1. Set the tuner frequency to the point of non-interference.
2. Connect the output of IF sweep generator to AM antenna terminal through IHF dummy and set the frequency to  $450 \pm 0.5$  kHz.
3. Connect the input of IF sweep generator to the test point TP3 through a 10  $\mu$ F cap.
4. Adjust T3 until the output waveform is flat and maximum.

#### TRACKING

1. Set the tuner frequency to 600 kHz.
2. Connect the output of signal generator to AM antenna terminal through IHF dummy and set the frequency to 600 kHz.
3. Connect the ACVM to TAPE OUT jacks.
4. Adjust T1 until the ACVM is maximum.
5. Change the tuner frequency from 600 kHz to 1400 kHz.
6. Change the frequency from 600 kHz to 1400 kHz.
7. Adjust TC1 until the ACVM is maximum.

#### SCAN STOP LEVEL

1. Set the tuner frequency to 1000 kHz.
2. Connect the DC digital volt meter to the test point TP4.
3. Set the input level to 54 dB/m.
4. Connect the output of signal generator to IRE loop antenna and set the frequency to 1000 kHz.
5. Adjust VR1 until the voltage changes 12 V from 0 V at the test point TP4.

### Tuner (FM)

#### Condition

1. Tuning method: Adjust desired signal frequency.  
Reception frequency, 98.00 MHz
2. Generator: Mono....Mod. 1 kHz, 75 kHz dev.  
Stereo...Mod. 1 kHz, 68.25 kHz +6.75 kHz dev.
3. TAPE OUT load: A 100 k $\Omega$  resistor shunted by a 1000 pF capacitor
4. Input level: 65.3 dBf (500  $\mu$ V) unless otherwise noted
5. De-Emphasis switch (SW51): 75  $\mu$ s position (EX version only)
6. AUTO SCAN switch: OFF position
7. Preheat: More than 1 minute

#### TUNING VOLTAGE

1. Set the tuner frequency to 87.50 MHz.
2. No input.
3. Connect the DC digital volt meter to the test point TP1.
4. Adjust OSC-L(Front-end) until the voltage is  $1.6 \pm 0.3$  V.
5. Change the tuner frequency from 87.50 MHz to 108.00 MHz.
6. Check that the voltage is between  $8.0 + 2.1$  V and  $8.0 - 1.0$  V.

#### IF & DETECTOR

1. Set the input level to 12.2~14.2 dBf (1.12~1.41  $\mu$ V).
2. Connect the output of signal generator to 75 ohm antenna terminal through a matching dummy and set the frequency to 98.00 MHz.
3. Connect the ACVM and the distortion meter to TAPE OUT jacks.
4. Connect the DC digital volt meter to the test point TP2.
5. Adjust IFT (Front-end) until the ACVM is maximum or the distortion meter is minimum.
6. Change the input level from 12.2~14.2 dBf (1.12~1.41  $\mu$ V) to 65.2 dBf (500  $\mu$ V).
7. Adjust T2 (a) until the voltage is less than 1 mV.
8. Adjust T2 (b) until the distortion meter is less than 0.3%.

#### TRACKING

1. Set the input level to 12.2~14.2 dBf (1.12~1.41  $\mu$ V).
2. Connect the output of signal generator to 75 ohm antenna terminal through a matching dummy and set the frequency to 98.00 MHz.
3. Connect the ACVM to TAPE OUT jacks.
4. Adjust ANT-L and RF1-L (Front-end) until the ACVM is maximum.

#### MUTING LEVEL

1. Connect the output of signal generator to 75 ohm antenna terminal through a matching dummy and set the frequency to 98.00 MHz.
2. Connect the DC digital volt meter to the test point TP4.
3. Set the input level to 33.2 dBf (12.5  $\mu$ V).
4. Adjust VR2 until the voltage changes 12 V from 0 V at the test point TP4.

#### SIGNAL LEVEL

1. Set the input level to 65.2 dBf (500  $\mu$ V).
2. Connect the output of signal generator to 75 ohm antenna terminal through a matching dummy and set the frequency to 98.00 MHz.
3. Adjust VR60 until the SIGNAL indicators fully light up.

#### SEPARATION

1. Connect the output of signal generator to 75 ohm antenna terminal through a matching dummy and set the frequency to 98.00 MHz in separate R ch or L ch.
2. Connect the ACVM to TAPE OUT jacks.
3. Adjust VR51 until both channels have maximum but equal separation.

#### FM A.C.C.D SWITCHING LEVEL

1. Set the input level to 55.2 dBf (158  $\mu$ V).
2. Connect the DC digital volt meter to the test point TP101.
3. Adjust VR101 the moment the voltage at TP101 change from +8 V to -8 V. Rotate VR101 slowly. Perform this adjustment after MUTING LEVEL adjustment.

#### FM A.C.C.D SEPARATION

1. Set the input level to 37.5 dBf (75  $\mu$ V).
2. Set generator Mod. 6.3 kHz, 49.5 kHz +6.75 kHz dev.
3. L ch only driven.
4. Connect the ACVM to TAPE OUT jacks.
5. A.C.C.D switch on.
6. Adjust VR117 to 8 dB separation.

ALIGNMENT POINTS

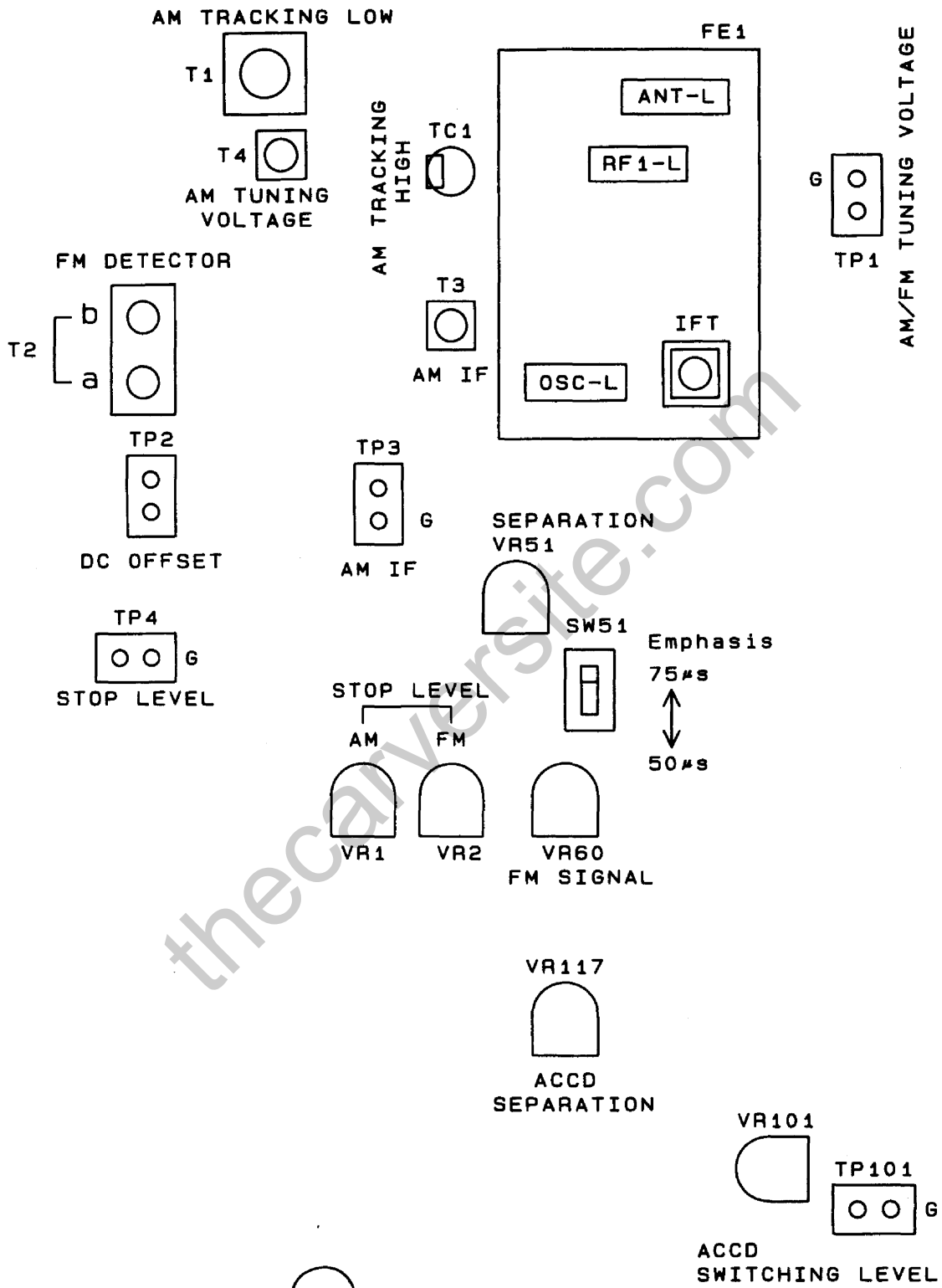

Fig.1

## VOLTAGE CONVERSION (EX Version only)

### 220 V/50 Hz Version

#### Bill of Materials

Q'ty	Part No.	Description
1	315-15005-00	FUSE 250 V 315 mA
1	530-10128-00	FUSE LABEL 250 V 315 mA
1	530-10088-00	LABEL 220 V AC 50 HZ
1	530-10087-00	LABEL VOLTAGE CONVERSION
1	530-10013-00	LABEL MILITARY CONVERSION

#### Directions for Change (120V to 220V)

- Locate Power Supply P.C.Board on the left side of the front panel(See Fig.2 ).
  - Set slide switch SW901 to the 220V position.
  - Change fuse FU901 from 250V 500 mA to 250 V 315 mA (315-15005-00).
  - Apply the label 530-10128-00 over the 250 V/500mA printing near the fuse.
- Locate CH STEP SW301 on the PLL P.C.Board and set it to "E" for 220 V European frequency stepping (See Fig.3).
- Locate de-emphasis SW51 on the AMPLIFIER/TUNER P.C.Board and set it to "50"  $\mu$ s for 220V European de-emphasis (See Fig.4).
- Apply the label 530-10088-00 over the 120V AC 60 Hz printing near the line cord.
- Using spray adhesive, mount the VOLTAGE CONVERSION label (530-10087-00) to the inside of the top cover.
- Apply the Military Conversion label (530-10013-00) to bottom of unit.

#### Directions for Change (220V to 120V)

- To convert from 220V to 120V, reverse the above procedure.
  - Set slide switch SW901 to 120V position.
  - Change fuse FU901 from 250V 315mA to 250V 500mA.
  - Remove the 250V 315mA label near the fuse.
- Set CH STEP SW301 on PLL PC Board to "US" position.
- Set de-emphasis SW51 on AMPLIFIER/TUNER P.C.Board to "75 $\mu$ s" position.
- Remove the 220V AC 50 Hz label near the linecord.

### PS-838B Power Supply P.C.Board

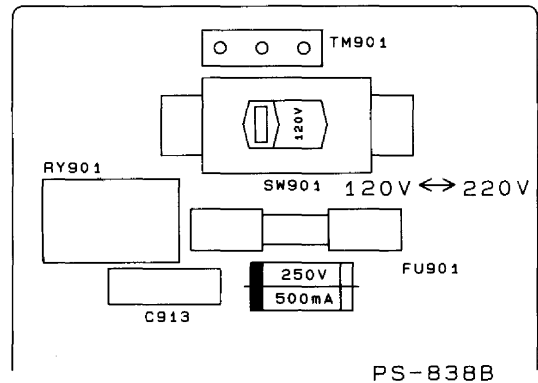

Fig.2

### FL-840 DTS P.C.Board

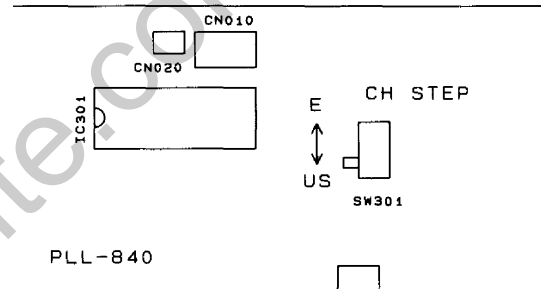

Fig.3

### MB-839B AMP & TUNER P.C.Board

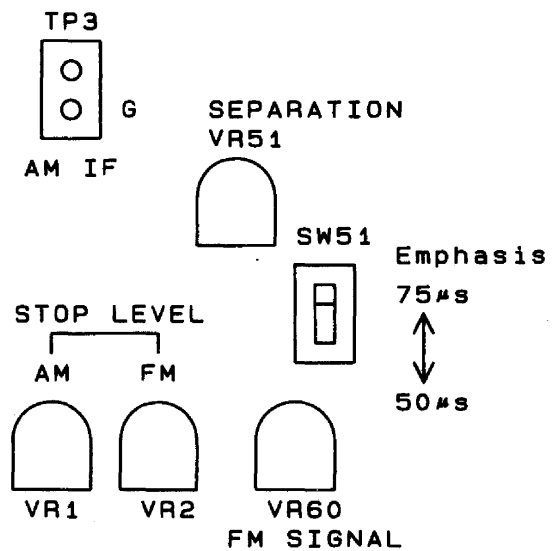
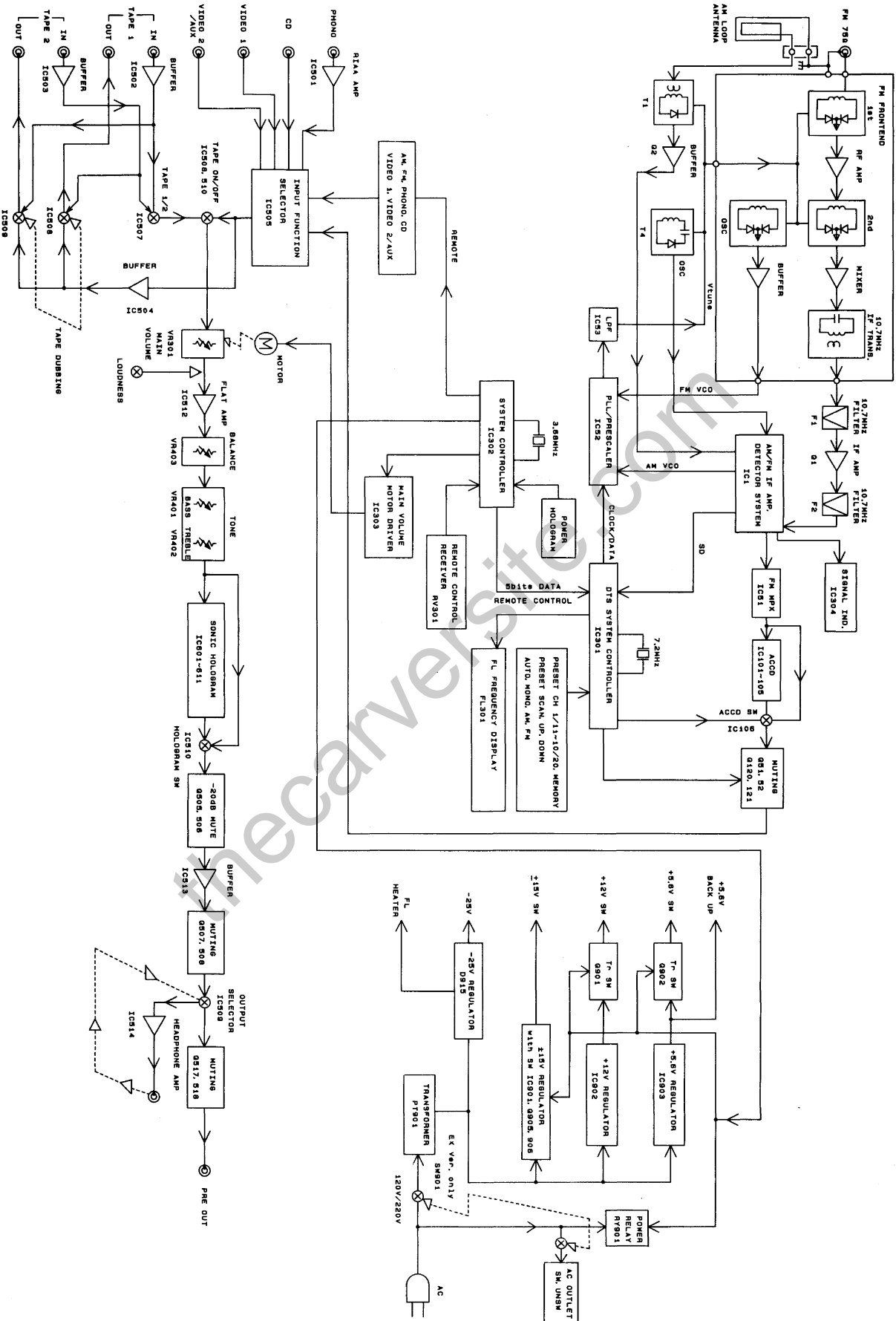

Fig.4

**BLOCK DIAGRAM**



# IC BLOCK DIAGRAM

## IC505 LC7818

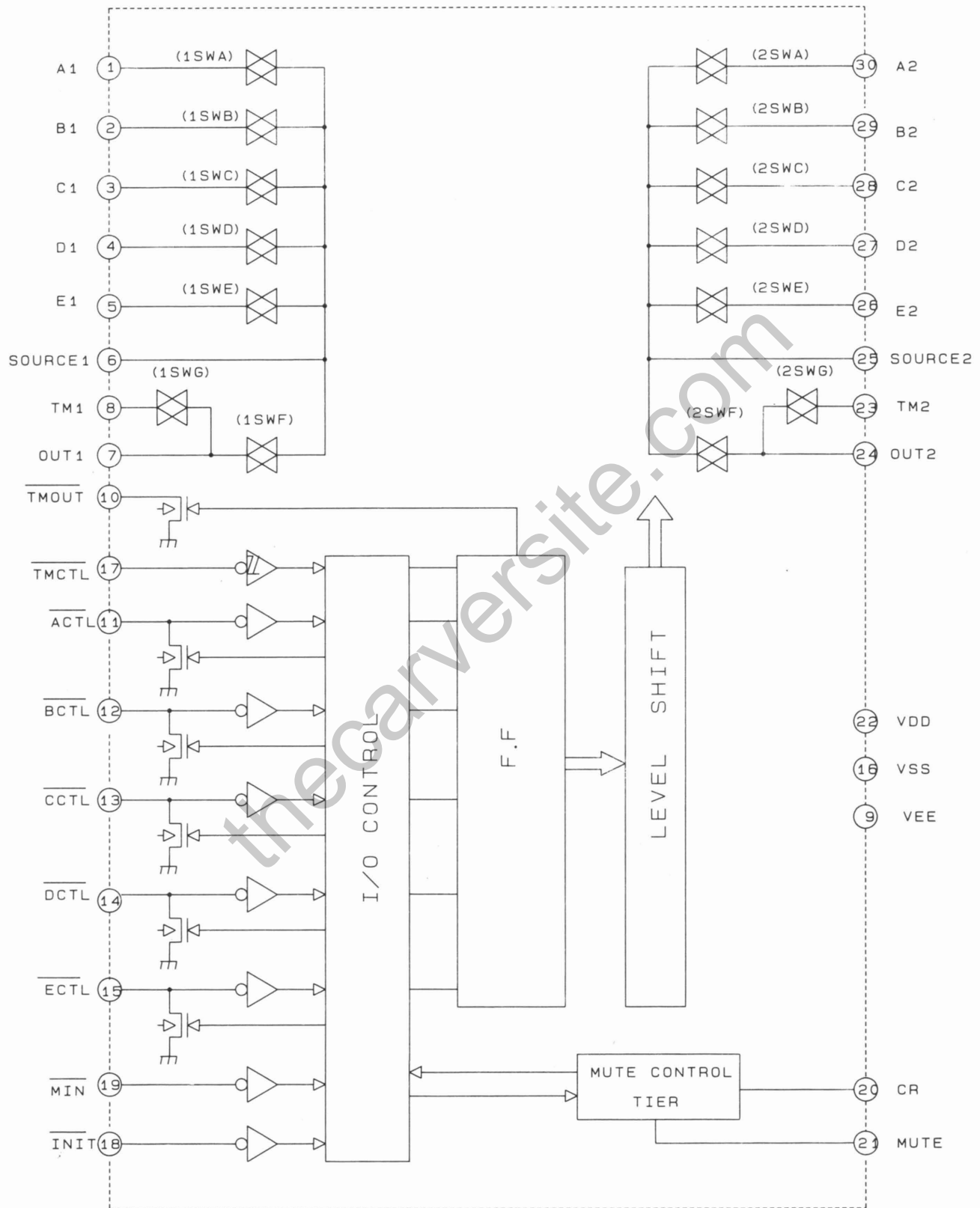

IC052 TC9172AP

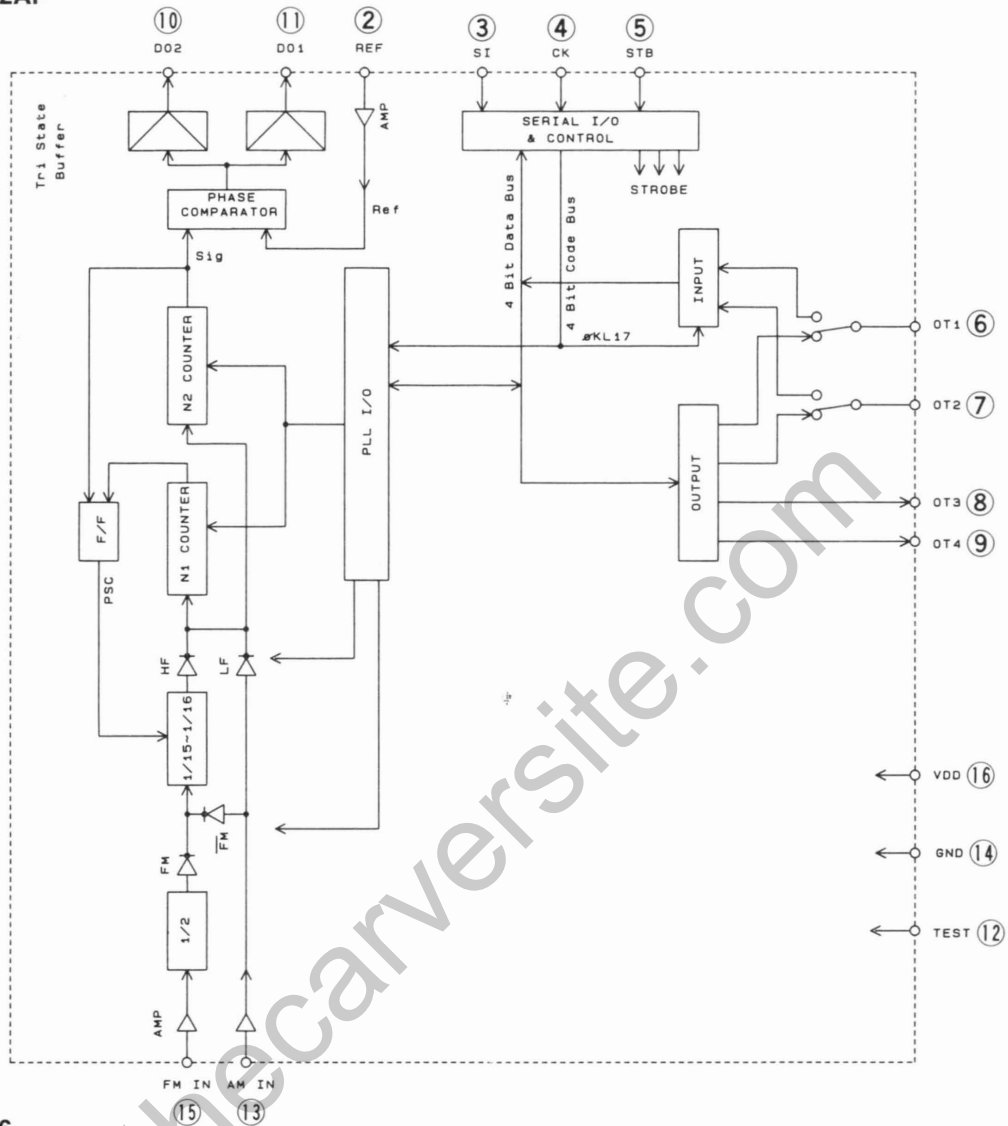

IC001 LA1266

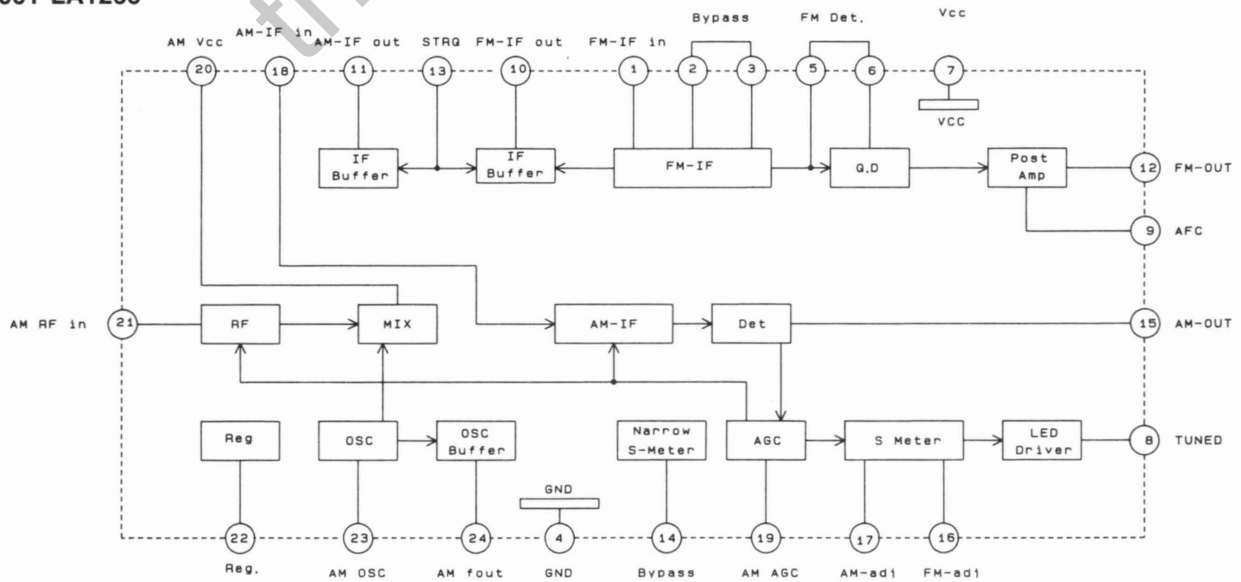

IC901 M5230L

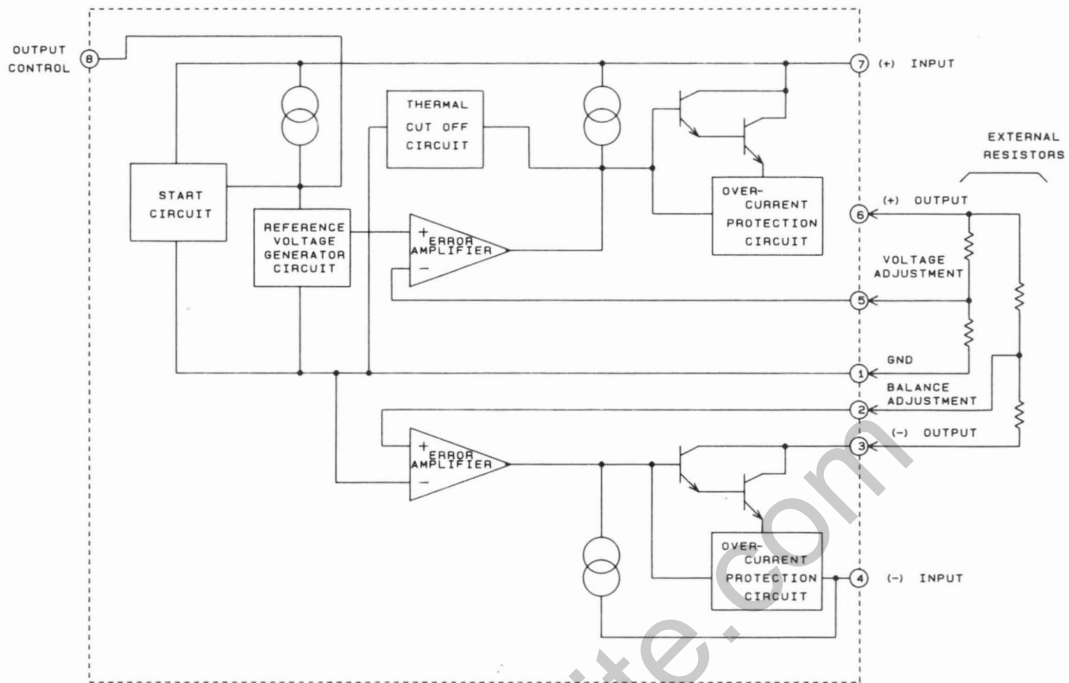

IC051 LA3401

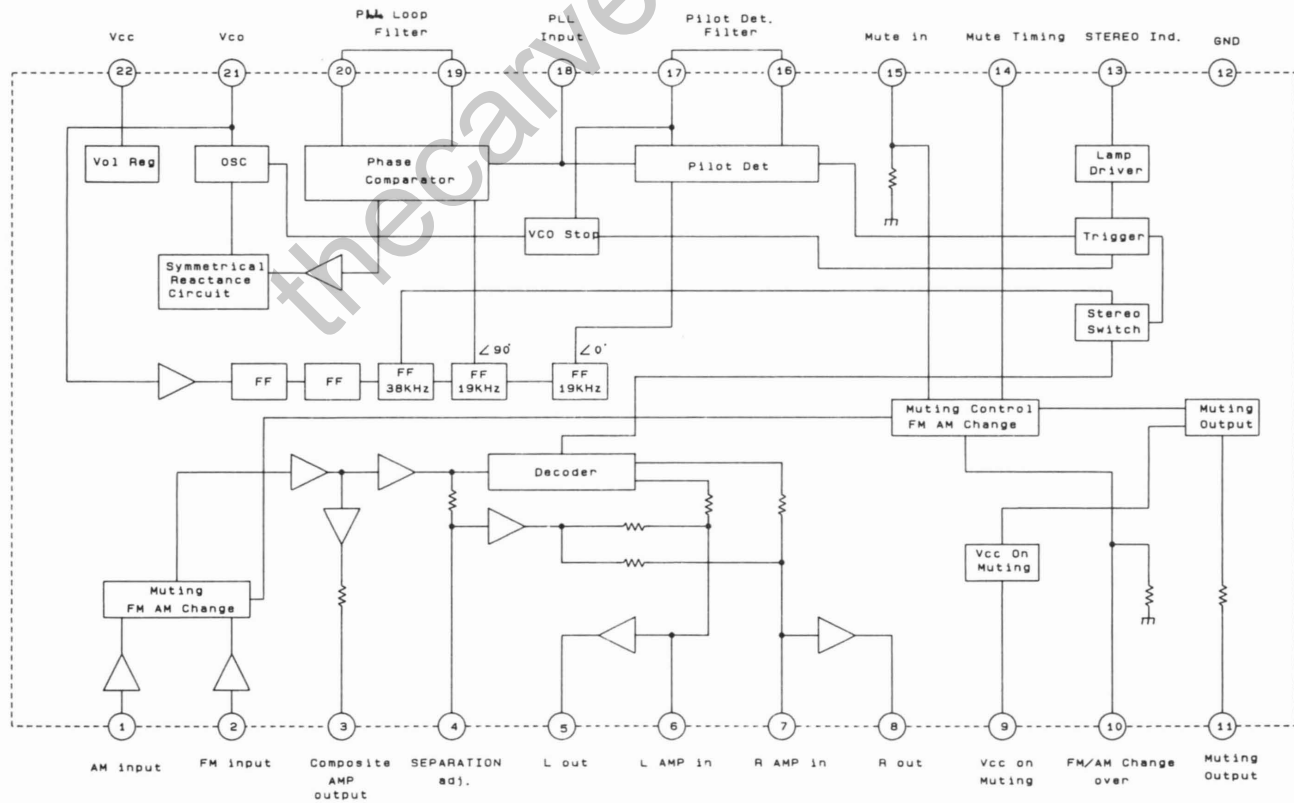

**IC303 LB1641**

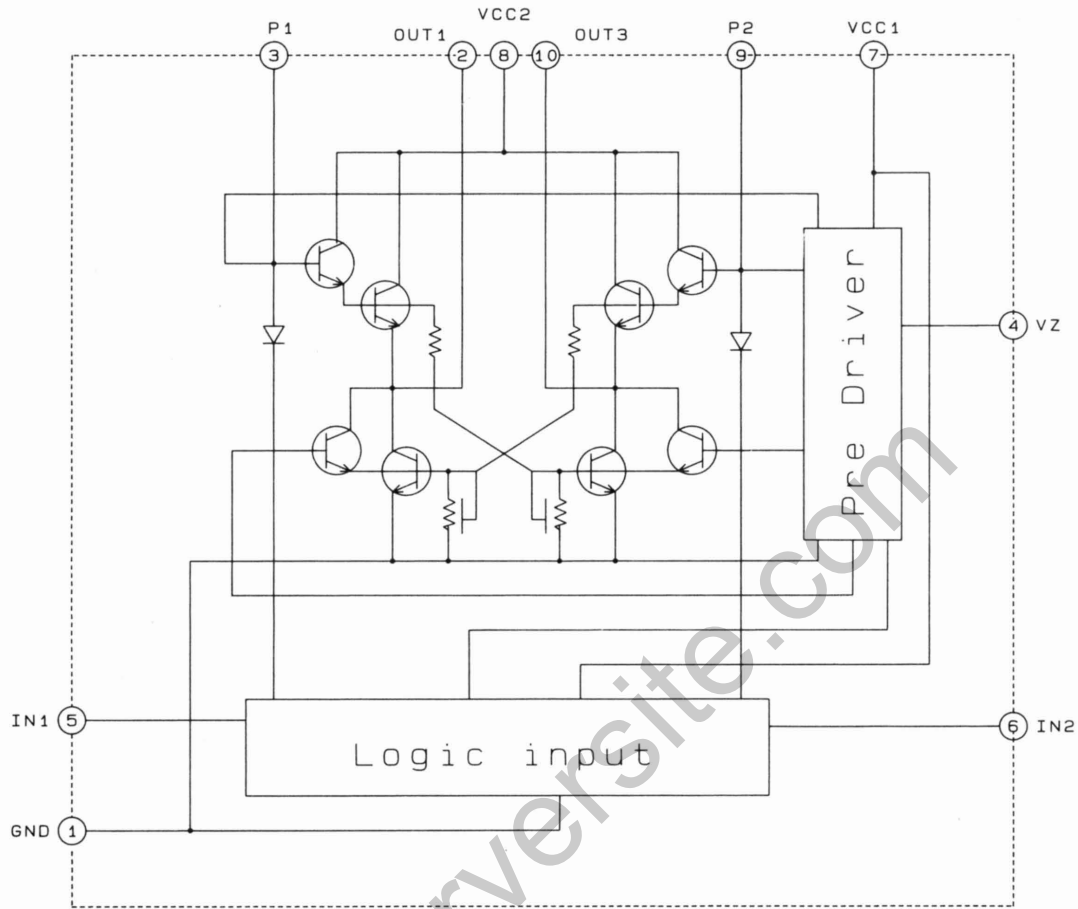

**IC507 TC9214P**

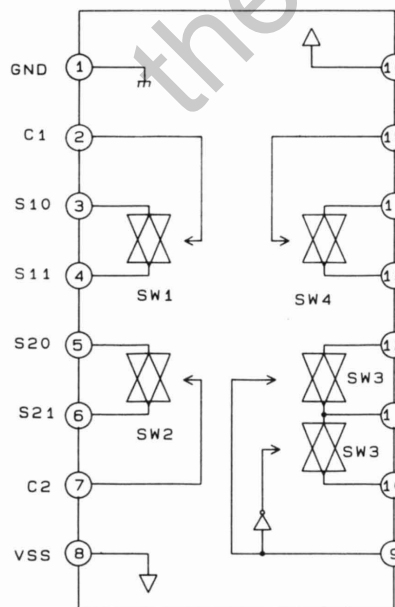

**IC508, 509, 510, 106 TC9215P**

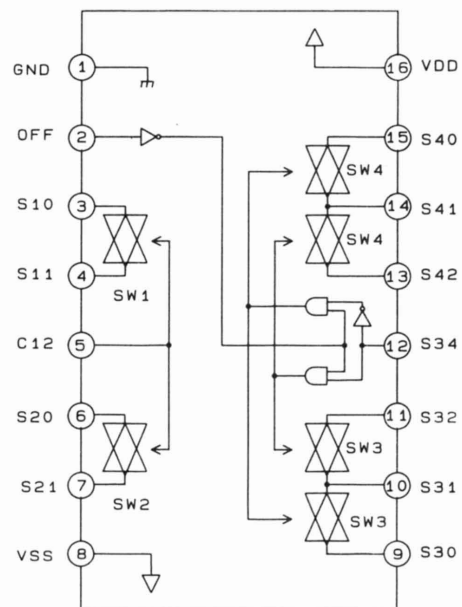

IC301 TC9303AN-014

VSS	1	GND	VDD	42	VDD
K0	2	K0	XT	41	XT
K1	3	K1	XT	40	XT
K2	4	K2	INH	39	INH
K3	5	K3	INT	38	INT
D0	6	G1	REF	37	REF
D1	7	G2	SI	36	SI
D2	8	G3	SO	35	SO
D3	9	G4	CK	34	CK
D4	10	G5	STB	33	STB
D5	11	G6	TEST	32	TEST
D6	12	G7	MUTE	31	MUTE
a	13	a	ASTOP	30	P1-2
b	14	b	AUTO	29	P2-4
c	15	c	ACCD	28	P2-3
d	16	d	STO	27	P2-2
e	17	e	R4	26	P2-1
f	18	f	R3	25	P3-4
g	19	g	R2	24	P3-3
h	20	h	R1	23	P3-2
-VFL	21	-VFL	R0	22	P3-1

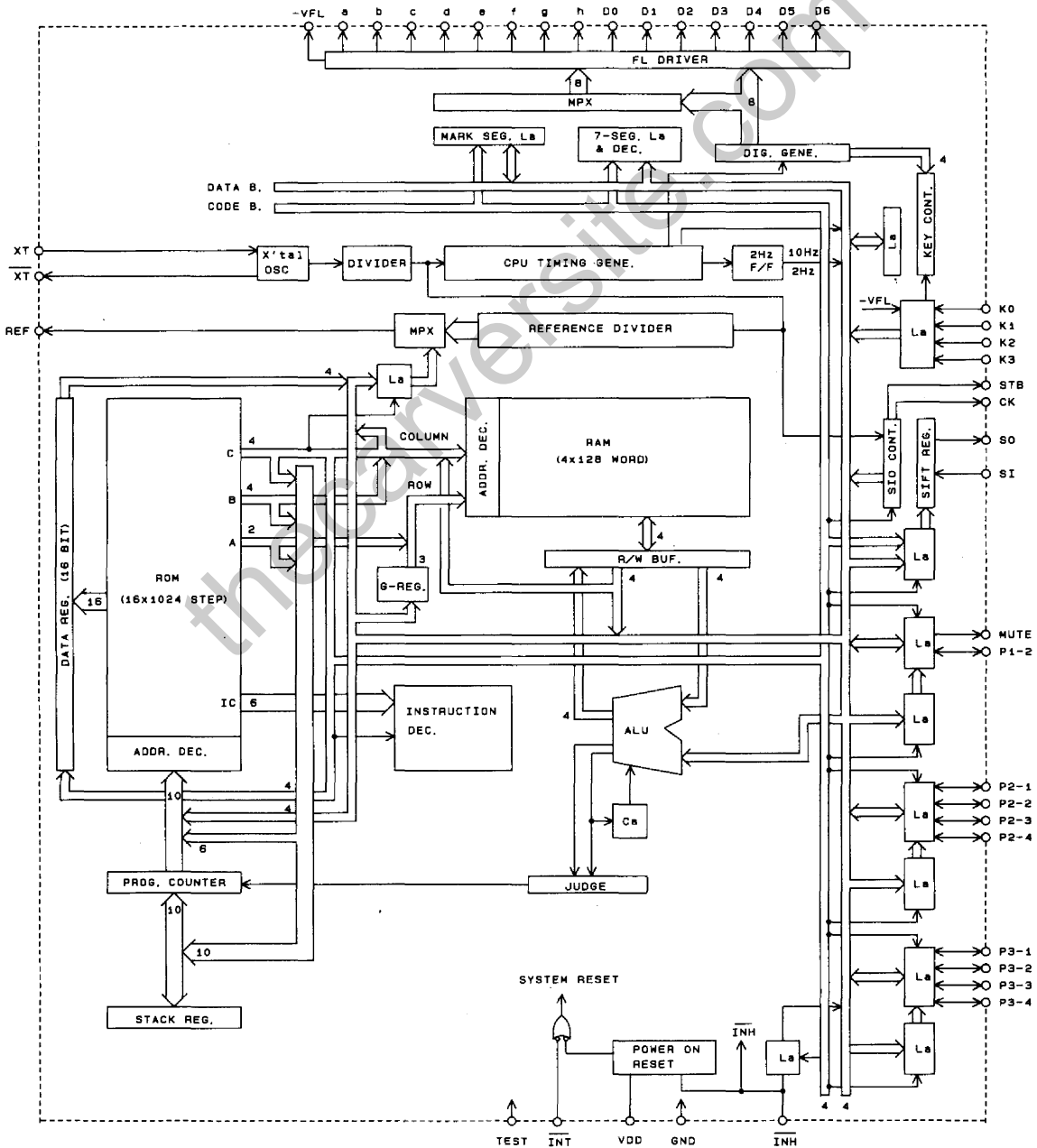

# IC302 LC6546C-4186

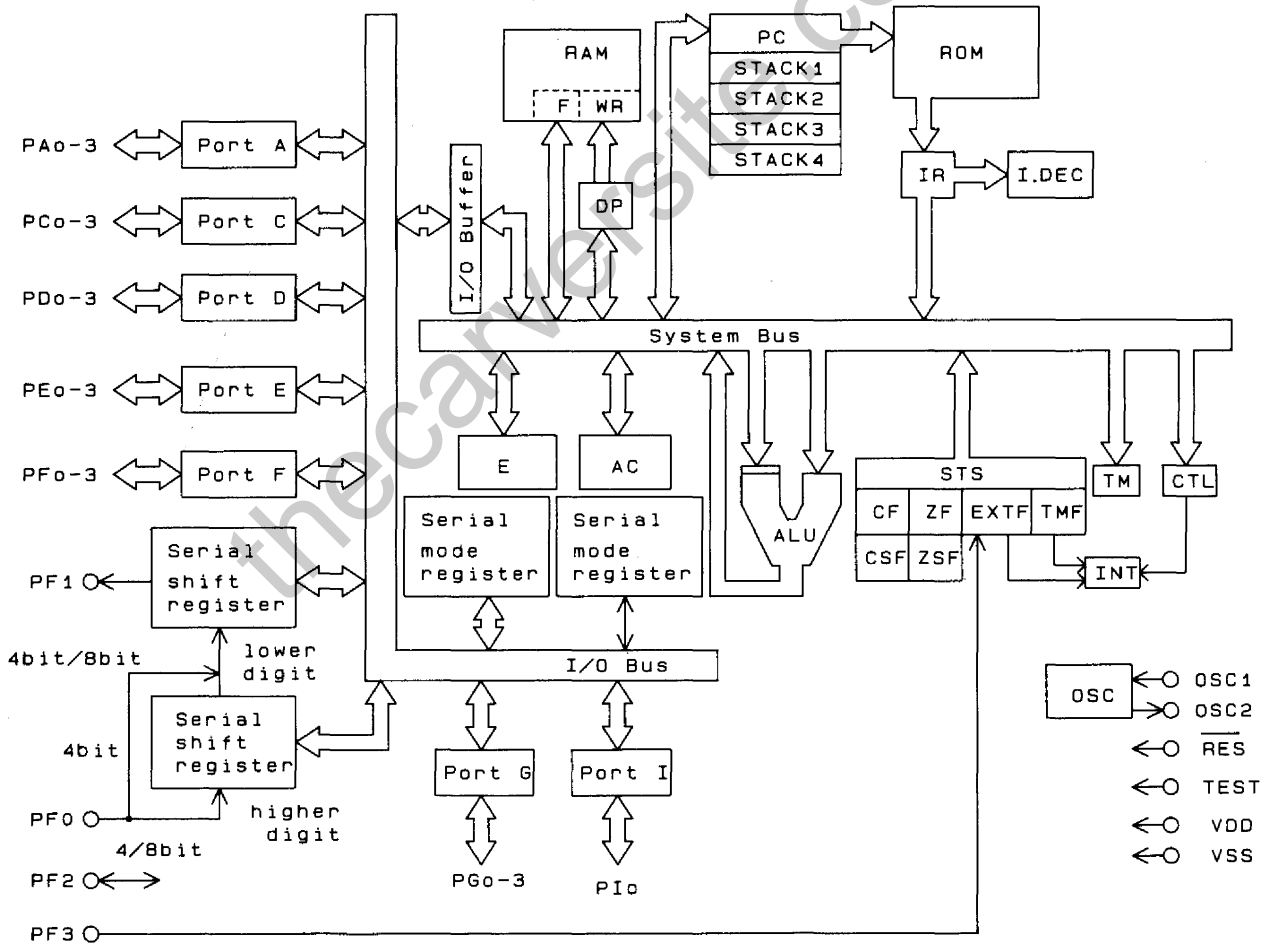
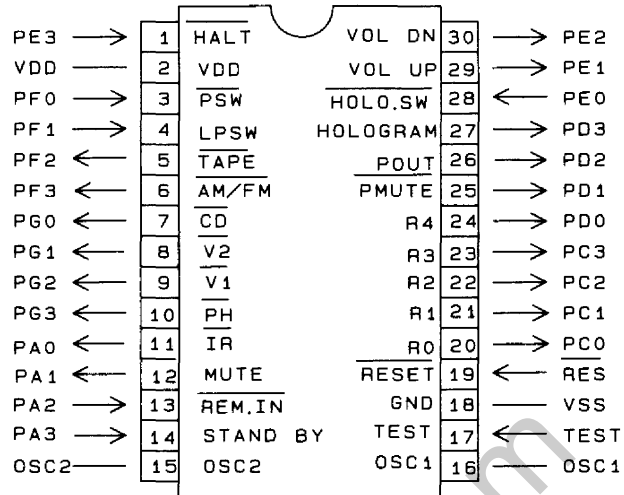

MB-839B Amp & Tuner P.C.Board

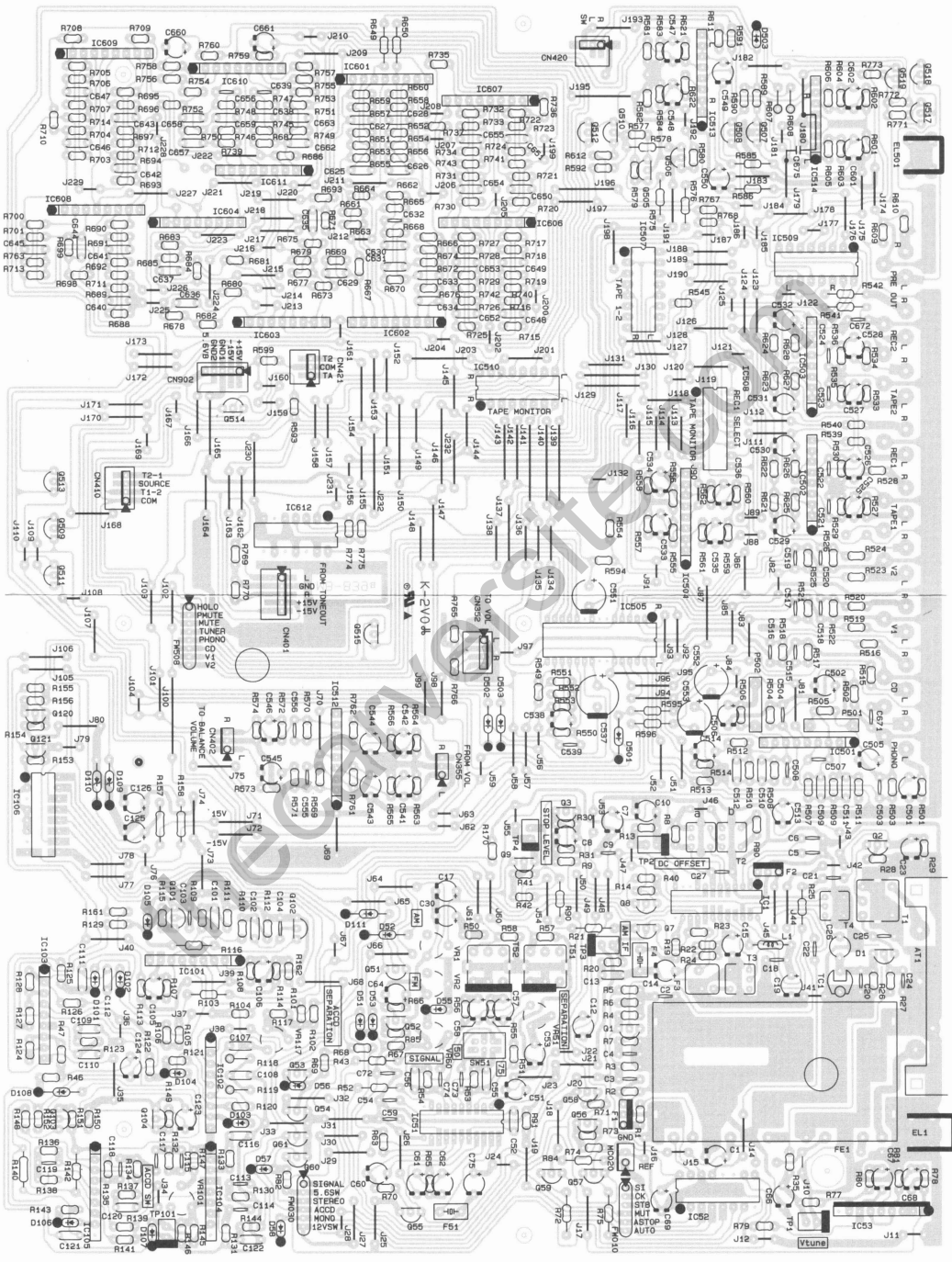

SW51, C73, 74: EX Version Only



PS-838B Power Supply P.C.Board

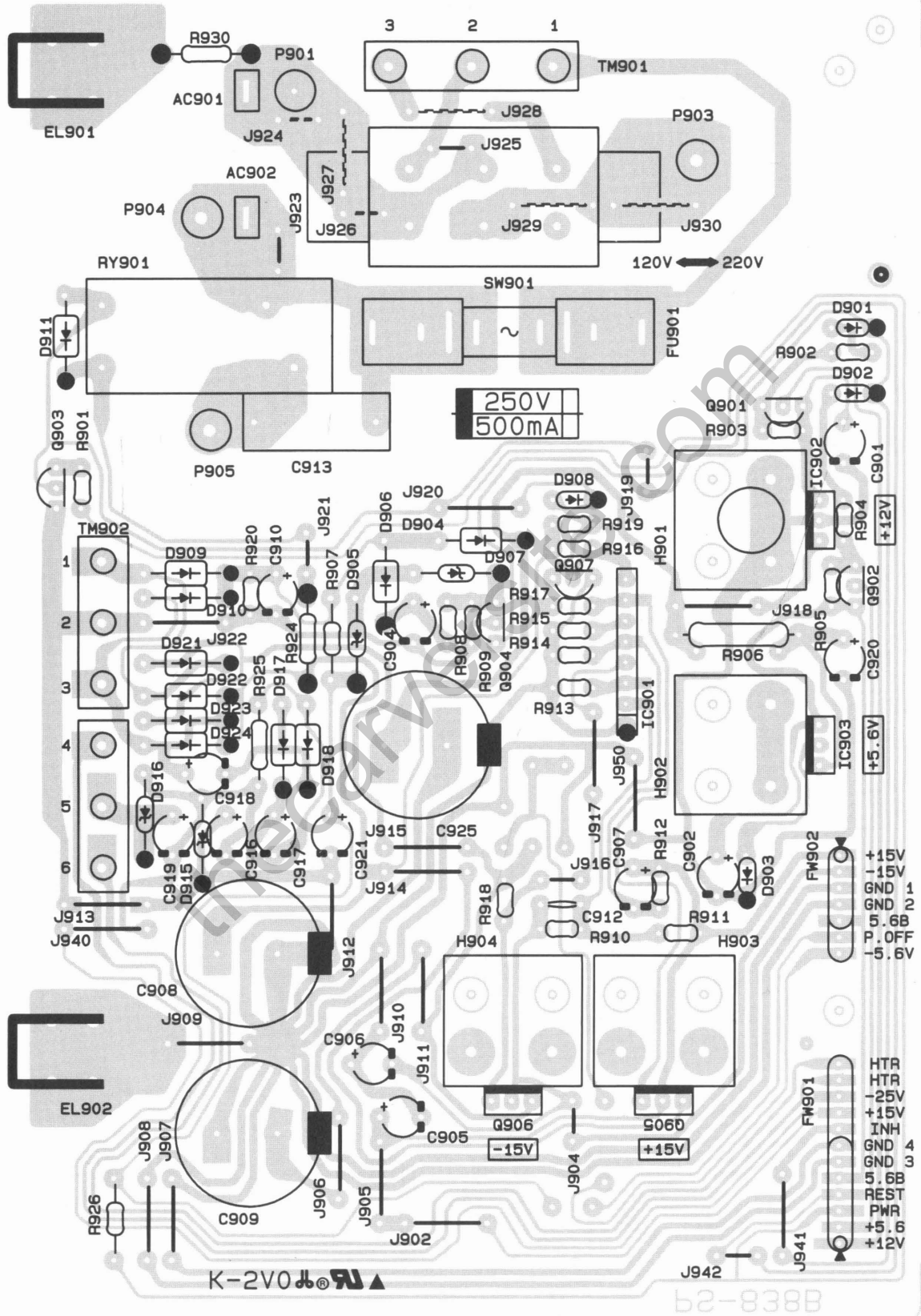

SW901, J924, 926, 927, 928, 929, 930: EX Version Only  
 J925: UL Version Only





# PARTS LIST

Parts marked with \* vary according to destinations and models. For details, refer to the different parts list.

## TONE AMP PCB ASS'Y

REF. NO.	Q'TY	CARVER PART NO.	DESCRIPTION
<b>P.C. BOARD</b>			
20E19	1	TON-838B	PRINTED CIRCUIT BOARD
<b>SEMICONDUCTORS</b>			
IC401	1	NJM4565SB	IC
<b>CAPACITORS</b>			
C401+402	2	50SMC334J	METALLIZED FILM CAPACITOR
C403+404	2	S7-25T4R7M	ELECTROLYTIC CAPACITOR
C405+406	2	MY-50VS822J	MYLAR CAPACITOR
C407+408	2	UPG50B101K	CERAMIC CAPACITOR
C409+410	2	S7-25T4R7M	ELECTROLYTIC CAPACITOR
C411+412	2	50SMC334J	METALLIZED FILM CAPACITOR
C413+414	2	S7-25T4R7M	ELECTROLYTIC CAPACITOR
C415+416	2	EP050Y103N	CERAMIC CAPACITOR
C431+432	2	MY-50VS473J	MYLAR CAPACITOR
C433+434	2	HE40SJY681K	CERAMIC CAPACITOR
<b>RESISTORS</b>			
R401+402	2	KA16ST562J	CARBON RESISTOR
R403+404	2	KA16ST152J	CARBON RESISTOR
R405+406	2	KA16ST562J	CARBON RESISTOR
R407+412	6	KA16ST152J	CARBON RESISTOR
R413+414	2	KA16ST562J	CARBON RESISTOR
R415+418	4	KA16ST274J	CARBON RESISTOR
R419+420	2	KA16ST104J	CARBON RESISTOR
R421+422	2	KA16ST562J	CARBON RESISTOR
R423+424	2	KA16ST471J	CARBON RESISTOR
R431+432	2	KA16ST153J	CARBON RESISTOR
R433+434	2	KA16ST473J	CARBON RESISTOR
<b>VR401+402</b>			
VR403	1	VBT09-203821K4	ROTARY POTENTIOMETER
		VBB09-154MNP4	ROTARY POTENTIOMETER
<b>SWITCHES</b>			
SW401	1	SW-1101301	PUSH SWITCH
<b>MISCELLANEOUS</b>			
1W19	1	651S265N18-J-Z	5-LEAD, FLAT CABLE
CN351	1	MZ05-843	MICRO SOCKET ASS'Y
MC402	1	MZ03-841	MICRO SOCKET ASS'Y
20E 5	1	E050	JUMP WIRE
20E 6	2	E100	JUMP WIRE

## POWER SUPPLY PCB ASS'Y

REF. NO.	Q'TY	CARVER PART NO.	DESCRIPTION
<b>P.C. BOARD</b>			
18E25	1	PS-838B	PRINTED CIRCUIT BOARD
<b>SEMICONDUCTORS</b>			
D901+903	3	1S5176	DIODE
D904	1	1N4002	DIODE
D905	1	ZD50-051	ZENER DIODE, 1/2W, 5.1V
D906	1	1N4002	DIODE
D907	1	ZD50-057	ZENER DIODE, 1/2W, 5.7V
D908	1	1S5176	DIODE
D909+911	3	1N4002	DIODE
D915	1	ZD50-245	ZENER DIODE, 1/2W, 24.5V
D916	1	ZD50-040	ZENER DIODE, 1/2W, 4V
D917, 918, 921-924	6	1N4002	DIODE
Q901+902	2	2SA966-0,Y	TRANSISTOR
Q903	1	2SC1815-Y,GR	TRANSISTOR
Q904	1	2SA1015-Y,GR	TRANSISTOR
Q905	1	2SB1274-R,S	TRANSISTOR
Q906	1	2SD1913-R,S	TRANSISTOR
Q907	1	RN-1204	TRANSISTOR
IC901	1	M5230L	IC
IC902	1	NJM78M12FA	IC
IC903	1	NJM78M05FA	IC
<b>CAPACITORS</b>			
C901+902	2	NS-25TW470M	ELECTROLYTIC CAPACITOR
C904	1	NS-50TW2R2M	ELECTROLYTIC CAPACITOR
C905+906	2	NS-16TW221M	ELECTROLYTIC CAPACITOR
C907	1	NS-50TW100M	ELECTROLYTIC CAPACITOR
C908+909	2	35MS16222M-KC	ELECTROLYTIC CAPACITOR
C910	1	NS-50TW2R2M	ELECTROLYTIC CAPACITOR
C912	1	HE40SJ5L100K	CERAMIC CAPACITOR
C913	1	YE103	METALLIZED FILM CAPACITOR
C916+917	2	NS-50TW100M	ELECTROLYTIC CAPACITOR
C918	1	NS-35TW470M	ELECTROLYTIC CAPACITOR
C919+920	2	NS-50TW100M	ELECTROLYTIC CAPACITOR
C921	1	NS-25TW470M	ELECTROLYTIC CAPACITOR
C925	1	35MS16222M-KC	ELECTROLYTIC CAPACITOR
<b>RESISTORS</b>			
R901	1	KA16ST102J	CARBON RESISTOR
R902	1	KA16ST222J	CARBON RESISTOR
R903	1	KA16ST104J	CARBON RESISTOR
R904	1	KA16ST152J	CARBON RESISTOR
R905	1	KA16ST104J	CARBON RESISTOR
R906	1	SA-1W1560J-LP	METAL OXIDE RESISTOR
R908	1	KA16ST103J	CARBON RESISTOR
R909	1	KA16ST223J	CARBON RESISTOR
R910+911	2	KA16ST153J	CARBON RESISTOR
R912	1	MF16ST243F	METAL FILM RESISTOR
R913	1	KA16ST561J	CARBON RESISTOR
R914	1	MF16ST332F	METAL FILM RESISTOR
R915	1	KA16ST561J	CARBON RESISTOR
R916	1	KA16ST105J	CARBON RESISTOR
R917+918	2	KA16ST101J	CARBON RESISTOR
R919	1	KA16ST473J	CARBON RESISTOR
R920	1	KA16ST223J	CARBON RESISTOR
R924	1	KA50XT271J	CARBON RESISTOR

REF. NO.	Q'TY	CARVER PART NO.	DESCRIPTION
R925	1	KA25ST152J	CARBON RESISTOR
R926	1	KA16ST472J	CARBON RESISTOR
R930	1	KA50XT335J	CARBON RESISTOR
<b>MISCELLANEOUS</b>			
H901-904	4	OSH-1623-B	HEAT SINK
1W 1	1	R-31Y16R28	CABLE ASS'Y
1W 2	1	R-31Y16Y25	CABLE ASS'Y
1W20+21	2	651S265N19-J-Z	5-LEAD, FLAT CABLE
1W26	1	651S267N19-J-Z	7-LEAD, FLAT CABLE
AC901	1	59BS4795	GND LUG
EL901+902	2	M1698	GND LUG
FU901	1	FU-625014-SM	FUSE
RY901	1	ONIT-55-112LM	RELAY
17E 1	2	CNT41-0013	FUSE HOLDER
18E19	7	E050	JUMP WIRE
18E20	19	E100	JUMP WIRE
18E23	1	I-103NA	TERMINAL PIN
18E24	1	I-756NA	TERMINAL PIN

## HEAD PHONE PCB ASS'Y

REF. NO.	Q'TY	CARVER PART NO.	DESCRIPTION
<b>P.C. BOARD</b>			
21E 3	1	HP-838B	PRINTED CIRCUIT BOARD
<b>SWITCHES</b>			
SW403	1	SW-1201302	PUSH SWITCH
<b>MISCELLANEOUS</b>			
1W12	1	651S263N30-J-Z	3-LEAD, FLAT CABLE
FW420	1	651S263N30-J-Z	3-LEAD, FLAT CABLE
HP401	1	YKB21-5008	MICK JACK

## DUBBING SW PCB ASS'Y

REF. NO.	Q'TY	CARVER PART NO.	DESCRIPTION
<b>P.C. BOARD</b>			
20E28	1	T08-838B	PRINTED CIRCUIT BOARD
<b>SWITCHES</b>			
SW402	1	SW-2134303	ROTARY SWITCH
<b>MISCELLANEOUS</b>			
1W16	1	651S264N15-J-Z	4-LEAD, FLAT CABLE

## MUTE LED PCB ASS'Y

REF. NO.	Q'TY	CARVER PART NO.	DESCRIPTION
<b>P.C. BOARD</b>			
15E24	1	VL-838B	PRINTED CIRCUIT BOARD
<b>SEMICONDUCTORS</b>			
D380	1	SPR-54MVWF	LED
<b>MISCELLANEOUS</b>			
MC380	1	MZ03-842	MICRO SOCKET ASS'Y

## AMP & TUNER PCB ASS'Y

REF. NO.	Q'TY	CARVER PART NO.	DESCRIPTION
<b>P.C. BOARD</b>			
27E27	1	MB-839B	PRINTED CIRCUIT BOARD
<b>SEMICONDUCTORS</b>			
D001	1	SVC342-L,M	DIODE
D051-053, 055-058, 101-108	15	1S5176	DIODE
D109+110	2	ZD50-090	ZENER DIODE, 1/2W, 9.0V
D111	1	1S5176	DIODE
D501-503	3	1S1588	DIODE
D504	1	1S5176	DIODE
Q001	1	25C2668-0,Y	TRANSISTOR
Q002	1	25K161-Y,GR	TRANSISTOR
Q003	1	2SA1015-Y,GR	TRANSISTOR
Q007	1	25C1815-Y,GR	TRANSISTOR
Q008	1	25K246-Y,GR	TRANSISTOR
Q009	1	RN-1204	TRANSISTOR
Q051	1	RN-2204	TRANSISTOR
Q052	1	25C1815-Y,GR	TRANSISTOR
Q053-055	3	RN-1204	TRANSISTOR
Q056	1	2SA966-0,Y	TRANSISTOR
Q057	1	25C1815-Y,GR	TRANSISTOR
Q058	1	RN-2204	TRANSISTOR
Q059	1	25C1815-Y,GR	TRANSISTOR
Q060+061	2	RN-1204	TRANSISTOR
Q101-103	3	25C1815-GR	TRANSISTOR
Q104	1	2SA1015-GR	TRANSISTOR
Q120+121, 505-508	6	25C2878-A,B	TRANSISTOR
Q509+510	2	RN-2204	TRANSISTOR
Q511+512	2	RN-1204	TRANSISTOR

REF. NO.	QTY	CARVER PART NO.	DESCRIPTION
Q513-515	3	RN-2204	TRANSISTOR
Q517,518	2	25C2878-A+B	TRANSISTOR
Q519	1	RN-2204	TRANSISTOR
IC001	1	LA1266	IC
IC051	1	LA3401	IC
IC052	1	TC9172AP	IC
IC053	1	NJM2904S	IC
IC101-105	5	NJM45655B	IC
IC106	1	TC9215P	IC
IC501	1	UPC4570HA-1	IC
IC502-504	3	NJM45655B	IC
IC505	1	LC7818	IC
IC507	1	TC9214P	IC
IC508-510	3	TC9215P	IC
IC512,513	2	NJM45655B	IC
IC514	1	M5216L	IC
IC601-604, 606-611	10	UPC4570HA-1	IC
IC612	1	TC4069UBP	IC
<b>CAPACITORS</b>			
C001	1	NS-16T101M	ELECTROLYTIC CAPACITOR
C002-006	5	HE90SJYF223Z	CERAMIC CAPACITOR
C007	1	NS-16T101M	ELECTROLYTIC CAPACITOR
C008	1	NS-50TW10M	ELECTROLYTIC CAPACITOR
C009	1	HE40SJSL330K	CERAMIC CAPACITOR
C010	1	NS-50TW10M	ELECTROLYTIC CAPACITOR
C012	1	NS-50TW22M	ELECTROLYTIC CAPACITOR
C013	1	MY-50VU102J	MYLAR CAPACITOR
C014,015	2	NS-16T100M	ELECTROLYTIC CAPACITOR
C017	1	NS-50TW10M	ELECTROLYTIC CAPACITOR
C018	1	HE90SJYF223Z	CERAMIC CAPACITOR
C019	1	NS-16T100M	ELECTROLYTIC CAPACITOR
C020	1	HE40SJSL100D	CERAMIC CAPACITOR
C021,022	2	HE90SJYF223Z	CERAMIC CAPACITOR
C023	1	NS-25T4W47M	ELECTROLYTIC CAPACITOR
C024	1	HE90SJYF223Z	CERAMIC CAPACITOR
C025	1	HE40SJSL110K	CERAMIC CAPACITOR
C026	1	ST-50VS471J	STYROL CAPACITOR
C027	1	HE90SJYF223Z	CERAMIC CAPACITOR
C030	1	NS-50TW10M	ELECTROLYTIC CAPACITOR
C051	1	NS-16T470M	ELECTROLYTIC CAPACITOR
C052	1	MY-50VU473J	MYLAR CAPACITOR
C053	1	NS-16T100M	ELECTROLYTIC CAPACITOR
C054	1	HE90SJYF223Z	CERAMIC CAPACITOR
* C055,056	2	MY-50VU102J	MYLAR CAPACITOR
C057,058	2	NS-16T100M	ELECTROLYTIC CAPACITOR
C059	1	HE90SJYF223Z	CERAMIC CAPACITOR
C060	1	NS-25T4W47M	ELECTROLYTIC CAPACITOR
C061	1	NS-50TW47M	ELECTROLYTIC CAPACITOR
C062,064	2	NS-50TW10M	ELECTROLYTIC CAPACITOR
C066	1	LL-50TW10M	LOW LEAK. ELECTROLYTIC CAP.
C067	1	LL-50TW47M	LOW LEAK. ELECTROLYTIC CAP.
C068	1	NS-16T100M	ELECTROLYTIC CAPACITOR
C069	1	NS-10T470M	ELECTROLYTIC CAPACITOR
C072	1	HE40SJYB471K	CERAMIC CAPACITOR
C075	1	NS-16T101M	ELECTROLYTIC CAPACITOR
C101,102	2	MY-50VU562J	MYLAR CAPACITOR
C103,104	2	HE50SJSL101K	CERAMIC CAPACITOR
C105,106	2	NS-25T4W47M	ELECTROLYTIC CAPACITOR
C107	1	MY-50VU103J	MYLAR CAPACITOR
C108	1	MY-50VU223J	MYLAR CAPACITOR
C109-112	4	S05MC104J	METALLIZED FILM CAPACITOR
C113	1	HE40SJYB561K	CERAMIC CAPACITOR
C114	1	HE40SJSL680K	CERAMIC CAPACITOR
C115	1	HE40SJSL470K	CERAMIC CAPACITOR
C116	1	MY-50VU182J	MYLAR CAPACITOR
C117	1	HE40SJYB561K	CERAMIC CAPACITOR
C118	1	HE40SJSL680K	CERAMIC CAPACITOR
C119	1	HE40SJSL560K	CERAMIC CAPACITOR
C120	1	MY-50VU182J	MYLAR CAPACITOR
C121,122	2	S05MC104J	METALLIZED FILM CAPACITOR
C123	1	NS-50TW3R3M	ELECTROLYTIC CAPACITOR
C124	1	NS-16T100M	ELECTROLYTIC CAPACITOR
C125,126	2	NS-10T101M	ELECTROLYTIC CAPACITOR
C501,502	2	NS-16T100M	ELECTROLYTIC CAPACITOR
C503,504	2	HE40SJYB101K	CERAMIC CAPACITOR
C505,506	2	NS-10T4721M	ELECTROLYTIC CAPACITOR
C507,508	2	HE50SJYB102K	CERAMIC CAPACITOR
C509,510	2	MY-50VU182J	MYLAR CAPACITOR
C511,512	2	MY-50VU562J	MYLAR CAPACITOR
C513,514	2	NS-16T100M	ELECTROLYTIC CAPACITOR
C515-524	10	HE40SJYB471K	CERAMIC CAPACITOR
C525-536	12	NS-25T4W47M	ELECTROLYTIC CAPACITOR
C537	1	NS-16T102M-KF	ELECTROLYTIC CAPACITOR
C538	1	NS-50TW47M	ELECTROLYTIC CAPACITOR
C539	1	HE12SJYF473Z	CERAMIC CAPACITOR
C541,542	2	NS-25T4W47M	ELECTROLYTIC CAPACITOR
C543,544	2	NS-10T4721M	ELECTROLYTIC CAPACITOR
C545-550	6	NS-25T4W47M	ELECTROLYTIC CAPACITOR
C551-553	3	NS-16T4721M	ELECTROLYTIC CAPACITOR
C555,556	2	HE40SJYB101K	CERAMIC CAPACITOR
C601,602	2	NS-25T4W47M	ELECTROLYTIC CAPACITOR
C625,626	2	MY-50VU332J	MYLAR CAPACITOR
C627,628	2	MY-50VU473J	MYLAR CAPACITOR
C629	1	MY-50VU823J	MYLAR CAPACITOR
C630,631	2	MY-50VU122J	MYLAR CAPACITOR
C632	1	HE40SJYB681K	CERAMIC CAPACITOR
C633	1	MY-50VU272J	MYLAR CAPACITOR
C634	1	MY-50VU124J	MYLAR CAPACITOR
C635	1	MY-50VU562J	MYLAR CAPACITOR
C636	1	MY-50VU883J	MYLAR CAPACITOR
C637	1	MY-50VU562J	MYLAR CAPACITOR
C638	1	MY-50VU222J	MYLAR CAPACITOR
C639	1	HE40SJYB221K	CERAMIC CAPACITOR
C640-655	16	MY-50VU102J	MYLAR CAPACITOR
C656	1	HE40SJYB221K	CERAMIC CAPACITOR
C657,658	2	MY-50VU182J	MYLAR CAPACITOR
C659	1	MY-50VU222J	MYLAR CAPACITOR
C660,661	2	NS-25T4W47M	ELECTROLYTIC CAPACITOR
C662,663	2	MY-50VU182J	MYLAR CAPACITOR
C671,672	2	HE12SJYF473Z	CERAMIC CAPACITOR
C675	1	HE90SJYF223ZLF	CERAMIC CAPACITOR

REF. NO.	QTY	CARVER PART NO.	DESCRIPTION
TC001	1	CTZ51C135	TRIMMER CAPACITOR
<b>RESISTORS</b>			
R001	1	KA16ST330J	CARBON RESISTOR
R002	1	KA16ST361J	CARBON RESISTOR
R003	1	KA16ST103J	CARBON RESISTOR
R004	1	KA16ST133J	CARBON RESISTOR
R005	1	KA16ST151J	CARBON RESISTOR
R006	1	KA16ST331J	CARBON RESISTOR
R007	1	KA16ST102J	CARBON RESISTOR
R008	1	KA16ST103J	CARBON RESISTOR
R009	1	KA16ST334J	CARBON RESISTOR
R013	1	KA16ST331J	CARBON RESISTOR
R014	1	KA16ST273J	CARBON RESISTOR
R019	1	KA16ST820J	CARBON RESISTOR
R020	1	KA16ST102J	CARBON RESISTOR
R021	1	KA16ST474J	CARBON RESISTOR
R022	1	KA16ST152J	CARBON RESISTOR
R023	1	KA16ST293J	CARBON RESISTOR
R024	1	KA16ST512J	CARBON RESISTOR
R025	1	KA16ST221J	CARBON RESISTOR
R026,027	2	KA16ST193J	CARBON RESISTOR
R028	1	KA16ST102J	CARBON RESISTOR
R029	1	KA16ST683J	CARBON RESISTOR
R030,031	2	KA16ST104J	CARBON RESISTOR
R035	1	KA16ST332J	CARBON RESISTOR
R040	1	KA16ST103J	CARBON RESISTOR
R041	1	KA16ST473J	CARBON RESISTOR
R042	1	KA16ST105J	CARBON RESISTOR
R043	1	KA16ST473J	CARBON RESISTOR
R046	1	KA16ST123J	CARBON RESISTOR
R047	1	KA16ST223J	CARBON RESISTOR
R050	1	KA16ST123J	CARBON RESISTOR
R051	1	KA16ST223J	CARBON RESISTOR
R052	1	KA16ST473J	CARBON RESISTOR
R053,054	2	KA16ST753J	CARBON RESISTOR
R055,056	2	KA16ST332J	CARBON RESISTOR
R057,058	2	KA16ST203J	CARBON RESISTOR
R063	1	KA16ST682J	CARBON RESISTOR
R065	1	KA16ST562J	CARBON RESISTOR
R066	1	KA16ST102J	CARBON RESISTOR
R067	1	KA16ST473J	CARBON RESISTOR
R068,069	2	KA16ST103J	CARBON RESISTOR
R070	1	KA16ST104J	CARBON RESISTOR
R071	1	KA16ST151J	CARBON RESISTOR
R072	1	KA16ST103J	CARBON RESISTOR
R073	1	KA16ST104J	CARBON RESISTOR
R074,075	2	KA16ST103J	CARBON RESISTOR
R077	1	KA16ST331J	CARBON RESISTOR
R078	1	KA16ST104J	CARBON RESISTOR
R079	1	KA16ST473J	CARBON RESISTOR
R080	1	KA16ST822J	CARBON RESISTOR
R081	1	KA16ST225J	CARBON RESISTOR
R082	1	KA16ST103J	CARBON RESISTOR
R084	1	KA16ST101J	CARBON RESISTOR
R085	1	KA16ST223J	CARBON RESISTOR
R090	1	KA16ST332J	CARBON RESISTOR
R091	1	KA16ST123J	CARBON RESISTOR
R091,102	2	KA16ST513J	CARBON RESISTOR
R103,104	2	KA16ST683J	CARBON RESISTOR
R105,106	2	KA16ST103J	CARBON RESISTOR
R107,108	2	KA16ST683J	CARBON RESISTOR
R109,110	2	KA16ST622J	CARBON RESISTOR
R111,112	2	KA16ST332J	CARBON RESISTOR
R113,114	2	KA16ST104J	CARBON RESISTOR
R115,116	2	KA16ST204J	CARBON RESISTOR
R117	1	KA16ST333J	CARBON RESISTOR
R118,119	2	KA25S106J	CARBON RESISTOR
R120	1	KA16ST113J	CARBON RESISTOR
R121	1	KA16ST184J	CARBON RESISTOR
R122	1	KA16ST153J	CARBON RESISTOR
R123	1	KA16ST154J	CARBON RESISTOR
R124	1	KA16ST333J	CARBON RESISTOR
R125,126	2	KA16ST105J	CARBON RESISTOR
R127,128	2	KA16ST472J	CARBON RESISTOR
R129	1	KA16ST103J	CARBON RESISTOR
R130	1	KA16ST512J	CARBON RESISTOR
R131	1	KA16ST513J	CARBON RESISTOR
R132	1	KA16ST433J	CARBON RESISTOR
R133	1	KA16ST52J	CARBON RESISTOR
R134	1	KA16ST512J	CARBON RESISTOR
R135	1	KA16ST513J	CARBON RESISTOR
R136	1	KA16ST273J	CARBON RESISTOR
R137	1	KA16ST152J	CARBON RESISTOR
R138	1	KA16ST132J	CARBON RESISTOR
R139	1	KA16ST103J	CARBON RESISTOR
R140	1	KA25T475J	CARBON RESISTOR
R141	1	KA16ST164J	CARBON RESISTOR
R142	1	KA16ST225J	CARBON RESISTOR
R143	1	KA16ST621J	CARBON RESISTOR
R144	1	KA16ST514J	CARBON RESISTOR
R145	1	KA16ST224J	CARBON RESISTOR
R146	1	KA16ST222J	CARBON RESISTOR
R147	1	KA16ST472J	CARBON RESISTOR
R148	1	KA16ST514J	CARBON RESISTOR
R149	1	KA16ST394J	CARBON RESISTOR
R150	1	KA16ST334J	CARBON RESISTOR
R151	1	KA16ST303J	CARBON RESISTOR
R152	1	KA16ST102J	CARBON RESISTOR
R153,154	2	KA16ST333J	CARBON RESISTOR
R155,156	2	KA16ST103J	CARBON RESISTOR
R157,158	2	KA25T181J	CARBON RESISTOR
R161,162	2	KA16ST102J	CARBON RESISTOR
R170	1	KA16ST104J	CARBON RESISTOR
R501,502	2	KA16ST220J	CARBON RESISTOR
R503,504	2	KA16ST473J	CARBON RESISTOR
R505,506	2	KA16ST911J	CARBON RESISTOR
R507,508	2	KA16ST433J	CARBON RESISTOR
R509,510	2	KA16ST514J	CARBON RESISTOR
R511,512	2	KA16ST391J	CARBON RESISTOR
R513,514	2	KA16ST473J	CARBON RESISTOR
R515,516	2	KA16ST561J	CARBON RESISTOR
R517,518	2	KA16ST105J	CARBON RESISTOR

REF. NO.	Q'TY	CARVER PART NO.	DESCRIPTION
R519+520	2	KA16ST561J	CARBON RESISTOR
R521+522	2	KA16ST105J	CARBON RESISTOR
R523+524	2	KA16ST561J	CARBON RESISTOR
R525+526	2	KA16ST105J	CARBON RESISTOR
R527+528	2	KA16ST561J	CARBON RESISTOR
R529+530	2	KA16ST473J	CARBON RESISTOR
R533+534	2	KA16ST561J	CARBON RESISTOR
R535+536	2	KA16ST473J	CARBON RESISTOR
R539+542	4	KA16ST471J	CARBON RESISTOR
R549	1	KA16ST103J	CARBON RESISTOR
R550	1	KA16ST224J	CARBON RESISTOR
R551+553	3	KA16ST104J	CARBON RESISTOR
R554	1	KA16ST221J	CARBON RESISTOR
R555+558	4	KA16ST474J	CARBON RESISTOR
R559+560	2	KA16ST224J	CARBON RESISTOR
R561+562	2	KA16ST471J	CARBON RESISTOR
R563+566	4	KA16ST224J	CARBON RESISTOR
R569+570	2	KA16ST822J	CARBON RESISTOR
R571+572	2	KA16ST471J	CARBON RESISTOR
R573+574	2	KA16ST473J	CARBON RESISTOR
R575+576	2	KA16ST392J	CARBON RESISTOR
R577+578	2	KA16ST103J	CARBON RESISTOR
R579+580	2	KA16ST391J	CARBON RESISTOR
R581+584	4	KA16ST224J	CARBON RESISTOR
R585+586	2	KA16ST621J	CARBON RESISTOR
R589+590	2	KA16ST103J	CARBON RESISTOR
R591+592	2	KA16ST105J	CARBON RESISTOR
R593	1	KA16ST104J	CARBON RESISTOR
R594	1	KA16ST473J	CARBON RESISTOR
R595+596	2	KA16ST221J	CARBON RESISTOR
R599	1	KA16ST103J	CARBON RESISTOR
R601+602	2	KA16ST224J	CARBON RESISTOR
R603+604	2	KA16ST104J	CARBON RESISTOR
R605+606	2	KA16ST224J	CARBON RESISTOR
R607+608	2	KA25S5151J	CARBON RESISTOR
R609+611	3	KA16ST104J	CARBON RESISTOR
R612	1	KA16ST103J	CARBON RESISTOR
R621	1	KA16ST471J	CARBON RESISTOR
R621	1	KA16ST473J	CARBON RESISTOR
R622	1	KA16ST471J	CARBON RESISTOR
R622+624	1	KA16ST473J	CARBON RESISTOR
R625+628	4	KA16ST471J	CARBON RESISTOR
R649+650	2	KA16ST203J	CARBON RESISTOR
R651+652	2	KA16ST362J	CARBON RESISTOR
R653+654	2	KA16ST332J	CARBON RESISTOR
R655+656	2	KA16ST392J	CARBON RESISTOR
R657+658	2	KA16ST822J	CARBON RESISTOR
R659+660	2	KA16ST203J	CARBON RESISTOR
R661+665	5	KA16ST392J	CARBON RESISTOR
R666	1	KA16ST912J	CARBON RESISTOR
R667	1	KA16ST392J	CARBON RESISTOR
R668	1	KA16ST203J	CARBON RESISTOR
R669	1	KA16ST183J	CARBON RESISTOR
R670	1	KA16ST203J	CARBON RESISTOR
R671	1	KA16ST362J	CARBON RESISTOR
R672	1	KA16ST103J	CARBON RESISTOR
R673+674	2	KA16ST102J	CARBON RESISTOR
R675	1	KA16ST392J	CARBON RESISTOR
R676	1	KA16ST112J	CARBON RESISTOR
R677	1	KA16ST302J	CARBON RESISTOR
R678+679	2	KA16ST392J	CARBON RESISTOR
R680	1	KA16ST183J	CARBON RESISTOR
R681	1	KA16ST162J	CARBON RESISTOR
R682+683	2	KA16ST392J	CARBON RESISTOR
R684	1	KA16ST162J	CARBON RESISTOR
R685	1	KA16ST302J	CARBON RESISTOR
R686	1	KA16ST273J	CARBON RESISTOR
R687	1	KA16ST682J	CARBON RESISTOR
R688	1	KA16ST512J	CARBON RESISTOR
R689	1	KA16ST752J	CARBON RESISTOR
R690	1	KA16ST203J	CARBON RESISTOR
R691	1	KA16ST752J	CARBON RESISTOR
R692	1	KA16ST122J	CARBON RESISTOR
R693	1	KA16ST512J	CARBON RESISTOR
R693	1	KA16ST273J	CARBON RESISTOR
R694	1	KA16ST752J	CARBON RESISTOR
R695	1	KA16ST203J	CARBON RESISTOR
R696	1	KA16ST752J	CARBON RESISTOR
R697	1	KA16ST122J	CARBON RESISTOR
R698	1	KA16ST512J	CARBON RESISTOR
R699	1	KA16ST752J	CARBON RESISTOR
R700	1	KA16ST203J	CARBON RESISTOR
R701	1	KA16ST752J	CARBON RESISTOR
R703	1	KA16ST512J	CARBON RESISTOR
R704	1	KA16ST752J	CARBON RESISTOR
R705	1	KA16ST203J	CARBON RESISTOR
R706	1	KA16ST752J	CARBON RESISTOR
R707	1	KA16ST122J	CARBON RESISTOR
R708	1	KA16ST752J	CARBON RESISTOR
R709+710	2	KA16ST105J	CARBON RESISTOR
R711	1	KA16ST361J	CARBON RESISTOR
R712	1	KA16ST301J	CARBON RESISTOR
R713+714	2	KA16ST361J	CARBON RESISTOR
R715	1	KA16ST512J	CARBON RESISTOR
R716	1	KA16ST752J	CARBON RESISTOR
R717	1	KA16ST203J	CARBON RESISTOR
R718	1	KA16ST752J	CARBON RESISTOR
R719	1	KA16ST122J	CARBON RESISTOR
R720	1	KA16ST512J	CARBON RESISTOR
R721	1	KA16ST752J	CARBON RESISTOR
R722	1	KA16ST203J	CARBON RESISTOR
R723	1	KA16ST752J	CARBON RESISTOR
R724	1	KA16ST122J	CARBON RESISTOR
R725	1	KA16ST512J	CARBON RESISTOR
R726	1	KA16ST752J	CARBON RESISTOR
R727	1	KA16ST203J	CARBON RESISTOR
R728	1	KA16ST752J	CARBON RESISTOR
R729	1	KA16ST122J	CARBON RESISTOR
R730	1	KA16ST512J	CARBON RESISTOR
R731	1	KA16ST752J	CARBON RESISTOR
R732	1	KA16ST203J	CARBON RESISTOR
R733	1	KA16ST752J	CARBON RESISTOR
R734	1	KA16ST122J	CARBON RESISTOR

REF. NO.	Q'TY	CARVER PART NO.	DESCRIPTION
R735	1	KA16ST752J	CARBON RESISTOR
R736+737	2	KA16ST103J	CARBON RESISTOR
R739	1	KA16ST692J	CARBON RESISTOR
R740	1	KA16ST361J	CARBON RESISTOR
R741	1	KA16ST301J	CARBON RESISTOR
R742+743	2	KA16ST361J	CARBON RESISTOR
R745+748	4	KA16ST303J	CARBON RESISTOR
R749+750	2	KA16ST133J	CARBON RESISTOR
R751+752	2	KA16ST153J	CARBON RESISTOR
R753+754	2	KA16ST102J	CARBON RESISTOR
R755+756	2	KA16ST511J	CARBON RESISTOR
R757+758	2	KA16ST470J	CARBON RESISTOR
R759+760	2	KA16ST473J	CARBON RESISTOR
R761+762	2	KA16ST102J	CARBON RESISTOR
R763	1	KA16ST122J	CARBON RESISTOR
R765+768	4	KA16ST104J	CARBON RESISTOR
R769+770	2	KA16ST224J	CARBON RESISTOR
R771+772	2	KA16ST103J	CARBON RESISTOR
R773	1	KA16ST105J	CARBON RESISTOR
R774+775	2	KA16ST104J	CARBON RESISTOR
VR001+002	2	SVR-06T3B303	SEMI-VARIABLE RESISTOR
VR051	1	SVR-06T3B104	SEMI-VARIABLE RESISTOR
VR060	1	SVR-06T3B204	SEMI-VARIABLE RESISTOR
VR101	1	SVR-06T3B103	SEMI-VARIABLE RESISTOR
VR117	1	SVR-06T3B104	SEMI-VARIABLE RESISTOR
COILS			
L001	1	LAL03102K	INDUCTOR
T001	1	126044	MW ANT COIL
T002	1	141039	FM DET COIL
T003	1	140058	MW IFT
T004	1	135023	MW OSC COIL
T051+052	2	184018	FILTER BLOCK
MISCELLANEOUS			
C675	1	HE90SJYF223ZLF	
F001+002	2	SFE10.7M21K-A	CERAMIC FILTER
F003	1	SFP450F	CERAMIC FILTER
F004	1	BFU450C4N	CERAMIC FILTER
F051	1	CSB456F11	CERAMIC FILTER
1W23	1	651S266N22-J-Z	6-LEAD, FLAT CABLE
1W24	1	651S266N46-J-Z	6-LEAD, FLAT CABLE
1W29	1	651S266N20-J-Z	8-LEAD, FLAT CABLE
AT001	1	YKD31-0426	SOCKET,CO-AXIAL
CN352	1	52007-0410	CONNECTOR
CN355	1	173981-3	MICRO PLUG
CN401	1	52007-0510	CONNECTOR
CN402	1	173981-3	MICRO PLUG
CN410	1	52007-0410	CONNECTOR
CN420+421	2	52007-0310	CONNECTOR
CN902	1	52007-0510	CONNECTOR
EL001+501	2	M1698	GND LUG
FE001	1	FE306-A28	FM FRONTEND
JK502	1	SH-R16613A	RCA JACK 6P
JK503+504	2	SH-R16613	RCA JACK 6P
MC020	1	MZ02-846	MICRO SOCKET ASS'Y
TP001-004, 101	5	IMS-A-1068-02A	MINI TERMINAL PLATE
TP501+502	2	IMS-A106802Z211	MINI TERMINAL PLATE
27E20	1	E125	JUMP WIRE
27E21	75	E050	JUMP WIRE
27E22	124	E100	JUMP WIRE
27E23	14	E150	JUMP WIRE
27E24	7	E200	JUMP WIRE

DTS & MICRO-COM PCB ASS'Y

REF. NO.	Q'TY	CARVER PART NO.	DESCRIPTION
P.C. BOARD			
13E20	1	PLL-840	PRINTED CIRCUIT BOARD
SEMI CONDUCTORS			
D301-304, 308+309, 311+312	8	15S176	DIODE
D314	1	ZD50-051	ZENER DIODE,1/2W,5.1V
D333-337	5	15S176	DIODE
Q301	1	25C1815-Y+GR	TRANSISTOR
Q302	1	RN-1204	TRANSISTOR
Q303-306	4	25C1815-Y+GR	TRANSISTOR
Q307-309	3	RN-2204	TRANSISTOR
Q310-312	3	RN-1204	TRANSISTOR
Q313-315	3	25C1815-Y+GR	TRANSISTOR
IC301	1	TC9303AN-014	IC
IC302	1	LC6546C-4186	IC
IC303	1	LB1641	IC
IC304	1	LB1423N	IC
CAPACITORS			
C301	1	J85R5TW222Y-KF	ELECTROLYTIC CAPACITOR!
C302	1	NS-10TW221M	ELECTROLYTIC CAPACITOR
C303+304	2	HE50SJCH270K	CERAMIC CAPACITOR
C305	1	NS-16TW100M	ELECTROLYTIC CAPACITOR
C306	1	NS-50TW100M	ELECTROLYTIC CAPACITOR
C307	1	NS-25TW4R7M	ELECTROLYTIC CAPACITOR
C308	1	NS-10TW470M	ELECTROLYTIC CAPACITOR

REF. NO.	Q'TY	CARVER PART NO.	DESCRIPTION
C309~311	3	HE90SJYF223Z	CERAMIC CAPACITOR
C312	1	NS-10TW221M	ELECTROLYTIC CAPACITOR
C313	1	NS-50TW1R0M	ELECTROLYTIC CAPACITOR
C314,315	2	HE50SJCH300J	CERAMIC CAPACITOR
C316	1	NS-16TW221M	ELECTROLYTIC CAPACITOR
C317,324~326	4	HE90SJYF223Z	CERAMIC CAPACITOR
C327	1	TP050F223Z	CERAMIC CAPACITOR
<b>RESISTORS</b>			
R301	1	KA16ST151J	CARBON RESISTOR
R302	1	KA16ST153J	CARBON RESISTOR
R303	1	KA16ST104J	CARBON RESISTOR
R304	1	KA16ST103J	CARBON RESISTOR
R305	1	KA16ST473J	CARBON RESISTOR
R306	1	KA16ST822J	CARBON RESISTOR
R307,308	2	KA16ST103J	CARBON RESISTOR
R308	1	KA16ST473J	CARBON RESISTOR
R309	1	KA16ST103J	CARBON RESISTOR
R309	1	KA16ST473J	CARBON RESISTOR
R310	1	KA16ST821J	CARBON RESISTOR
R311~313	3	KA16ST93J	CARBON RESISTOR
R322,323	2	KA16ST821J	CARBON RESISTOR
R324~332	9	KA16ST104J	CARBON RESISTOR
R333,334	2	KA16ST103J	CARBON RESISTOR
R335	1	KA16ST472J	CARBON RESISTOR
R337	1	KA16ST103J	CARBON RESISTOR
R338	1	KA16ST393J	CARBON RESISTOR
R339~341	3	KA16ST103J	CARBON RESISTOR
R342	1	KA16ST471J	CARBON RESISTOR
R343	1	KA16ST221J	CARBON RESISTOR
R344	1	KA16ST100J	CARBON RESISTOR
R345	1	KA50XT680J	CARBON RESISTOR
<b>MISCELLANEOUS</b>			
P301,302	2	6029B-1-122015	CONNECTOR
P303	1	6029B-1-092015	CONNECTOR
P304	1	6029B-1-082015	CONNECTOR
P305	1	6029B-1-072015	CONNECTOR
X301	1	HC18/U7.200MHZ	QUARTZ OSCILLATOR UNIT
X302	1	CSA3.68MG	CERAMIC OSCILLATOR UNIT
CN010	1	52007-0610	CONNECTOR
CN020	1	P125C02M	MICRO PLUG
CN030	1	52007-0610	CONNECTOR
CN354,360	2	52007-0310	CONNECTOR
CN380	1	P122A03M	CONNECTOR
CN508	1	52007-0810	CONNECTOR
CN901	1	52007-1210	CONNECTOR
12E29	19	E050	JUMP WIRE
12E30	11	E075	JUMP WIRE
13E 1	42	E100	JUMP WIRE
13E 2	19	E125	JUMP WIRE

INDICATOR & SW PCB ASS'Y

REF. NO.	Q'TY	CARVER PART NO.	DESCRIPTION
<b>P.C. BOARD</b>			
15E 4	1	DPY-840	PRINTED CIRCUIT BOARD
<b>SEMICONDUCTORS</b>			
D305~307, 310	4	15S176	DIODE
D315~317	3	SLR-37DU3F	LED
D318	1	SLB-15VR3F	LED
D319~321	3	SLR-37VR3F	LED
D322~324	3	SLR-37DU3F	LED
D325	1	SLR-37VR3F	LED
D326~327	2	SLR-37DU3F	LED
D328,329	2	SLR-37VR3F	LED
<b>CAPACITORS</b>			
C320~323	4	TP050F223Z	CERAMIC CAPACITOR
<b>RESISTORS</b>			
R314	1	KA16ST821J	CARBON RESISTOR
R315~319	5	KA16ST182J	CARBON RESISTOR
R320,321, 346	3	KA16ST821J	CARBON RESISTOR
<b>SWITCHES</b>			
SW301~314	14	SOA-124HS-RT	TACT SWITCH
SW315~319, 321~324	9	SOK-174HS-RT	TACT SWITCH
SW325	1	SOA-124HS-RT	TACT SWITCH
<b>MISCELLANEOUS</b>			
BC301,302	2	52084-1210	CONNECTOR
BC303	1	52084-0910	CONNECTOR
BC304	1	52084-0810	CONNECTOR
BC305	1	52084-0710	CONNECTOR
FL301	1	FGR7851	FLUORESCENCE LAMP
RV301	1	SPS-420	REMOTE CONTROL RECEIVER
14E24	11	E050	JUMP WIRE
14E25	7	E075	JUMP WIRE
14E26	6	E100	JUMP WIRE
14E27	1	E125	JUMP WIRE

POWER SW PCB ASS'Y

REF. NO.	Q'TY	CARVER PART NO.	DESCRIPTION
<b>P.C. BOARD</b>			
15E15	1	PSW-840	PRINTED CIRCUIT BOARD
<b>SWITCHES</b>			
SW327	1	SOA-124HS-RT	TACT SWITCH
<b>MISCELLANEOUS</b>			
1W11	1	651S263N30-J-Z 3-LEAD	FLAT CABLE

MAIN VOLUME PCB ASS'Y

REF. NO.	Q'TY	CARVER PART NO.	DESCRIPTION
<b>P.C. BOARD</b>			
22E10	1	VR-840	PRINTED CIRCUIT BOARD
<b>CAPACITORS</b>			
C318	1	HE90SJYF223Z	CERAMIC CAPACITOR
<b>RESISTORS</b>			
VR301	1	VBV16-1048TNF5	ROTARY POTENTIOMETER
<b>MISCELLANEOUS</b>			
1W 9	1	651S262N068C-J 2-LEAD	FLAT CABLE
1W14	1	651S263N08-J-Z 3-LEAD	FLAT CABLE
1W18	1	651S264N28-J-Z 4-LEAD	FLAT CABLE
MC351	1	173981-5	MICRO PLUG
MC355	1	MZ03-840	MICRO SOCKET ASS'Y

EXPLODED VIEW

REF. NO.	Q'TY	CARVER PART NO.	DESCRIPTION
<b>P.C. BOARD</b>			
AH951	1	LA-75K	ANTENNA HOLDER
<b>CAPACITORS</b>			
C951	1	YE103	METALLIZED FILM CAPACITOR
<b>COILS</b>			
LP951	1	171006	LOOP ANT
<b>PT951</b>			
PT951	1	NPT-2904S	POWER TRANSFORMER
<b>MISCELLANEOUS</b>			
E451	1	R-020-10	CABLE ASS'Y
1M 1	1	N31148-1	FRONT PANEL R
1M 2	1	N45856-1	FRONT PANEL L
1M 3	2	N45858-BK1	HANDDL
1M 5	1	N10587-1	FRONT BASE
1M 6	4	N45846	HANDLE SPACER
1M 8	3	N44260-T-BK1	KNOB 12
1M 9	1	N45859-T-BK1	KNOB 12
1M10	1	N31110-T-BK1	KNOB 33
1M11	7	N31152-BK	TACT BUTTON
1M12	2	N31153-BK	TACT BUTTON
1M14	2	N45668	TACT BUTTON
1M15	1	N45668-2	TACT BUTTON
1M16	1	N45668-1	TACT BUTTON
1M19	3	N45646A	PUSH BUTTON
1M21	1	N45522	LED CHIP
1M22	1	N31150-1	FRONT GLASS
1M24	1	N10589	CABINET
1M26	1	N21861-1A	REAR PANEL
1M27	1	N10590A	BOTTOM CHASSIS
1M28	4	7102B	FOOT
2M 1	1	N45871	VR METAL
2M 4	1	N45546	FITTINGS (HEAD PHONE JACK)
2M 6	1	N31155	LED HOLDER
2M 7	1	N45860	LED HOLDER
2M 8	1	N31154	FL HOLDER
2M10	1	BPS-315	LED SPACER
2M12	1	N45695	CUSHION
2M13	1	N40848G	SHAFT TAPE
2M16	1	N45901-1	POLYETHYLENE BAG
2M17	1	N40487	POLYETHYLENE BAG(ACCESSORIES)
2M18	1	N21865A	PACKING PAD,F
2M19	1	N21866A	PACKING PAD,R
2M20	1	N21867-1	INNER CARTON
2M22	1	0M-964	INSTRUCTION MANUAL
2M23,M24	2	N45335	LABEL,SERIAL NO.
2M25	1	N45882	LABEL,CAUTION
2M26	1	N41937	LABEL,FUSE
2M27	1	N31136	WARRANTY R
2M28	1	N31137	LIMITED WARRANTY
2M29	2	N42235	SHEET, SERIAL NUMBER
2M30	1	N45914	LABEL,UL (VIDEO)
3M 1~M 4	10	T88+26X08-Y	TAP SCREW B, BIND HEAD, Y
3M11~M16	23	T88+30X08-B	TAP SCREW B, BIND HEAD, B
4M 1~M 3	8	T85+30X08-B	TAP SCREW S, BIND HEAD, B
4M 7~M 8	6	T85+30X08-B	TAP SCREW B, FLAT HEAD, B
4M16	1	T88+30X06-N	TAP SCREW B,BIND HEAD N
4M21	4	TST+40X08-Y	TAP SCREW S, TRUSS, Y
4M25	4	SS312+40X14-B	SCREW-SP ASSY,P HEAD B
4M29	2	2AWX0830-05-B	PLAIN WASHER, B

REF. NO.	Q'TY	CARVER PART NO.	DESCRIPTION
GT951	1	YK041-0004	GROUND TERMINAL
15E 6	2	KGLS-16RT	LOCKING SUPPORT
27E25	6	KGLS-6RT	SPACER
28E 2	1	SR-4N-4	CORD STOPPER
28E 5	1	ACC-02204-4EE1	LINE CORD
28E 9	1	TANT-064	FM ANTENNA (CORD)
28E10	1	YAE21-0001D	MATCHING ADAPTOR
28E12	1	RC-HR752	REMOTE CONTROL TRANSMITTER
28E13	1	UM-4-2	BATTERY
28E15	2	KGLS-10RT	SPACER
AC0951,952	2	AC-T05F847	AC OUTLET

OTHER PARTS

REF. NO.	Q'TY	CARVER PART NO.	DESCRIPTION
MISCELLANEOUS			
* 1W 3	1	015Y160B25MFMF	WIRE
1W 5	1	015Y160B08MFMF	WIRE
28E20	1	OP-80	CORD CLAMP
28E21	8	NO-5167	CORD CLAMP
28E22	5	BK-1	CORD CLAMP

P.C. BOARD ASS'Y

REF. NO.	Q'TY	CARVER PART NO.	DESCRIPTION
13P20	1	PLL-840	DTS & MICRO-COM PCB ASS'Y
15P 4	1	DPY-840	INDICATOR & SW PCB ASS'Y
15P15	1	PSW-840	POWER SW PCB ASS'Y
15P24	1	VL-839B	MUTE LED PCB ASS'Y
18P25	1	PS-838B	POWER SUPPLY PCB ASS'Y
20P19	1	TON-838B	TONE AMP PCB ASS'Y
20P28	1	TDB-838B	DUBBING SW PCB ASS'Y
21P 3	1	HP-838B	HEAD PHONE PCB ASS'Y
22P10	1	VR-840	MAIN VOLUME PCB ASS'Y
27P27	1	HB-839B	AMP & TUNER PCB ASS'Y

DIFFERENT PARTS LIST

Ref.No.	Description	CT-6 (UL)	CT-6 (EX)	PSC-60
POWER SUPPLY PCB ASS'Y				
SW901	SWITCH	-	SW-5220218	-
AC902	GND LUG	-	59BS4795	-
AMP & TUNER PCB ASS'Y				
SW051	SLIDE SWITCH	-	SW-5221306	-
C055,056	MYLAR CAPACITOR	MY-50VU102J	-	MY-50VU102J
C055,056	CERAMIC CAPACITOR	-	HE11SJS1681J	-
C073,074	CERAMIC CAPACITOR	-	HE80SJS1331J	-
DTS & MICRO-COM PCB ASS'Y				
D331,332	DIODE	-	1SS176	-
OTHER PARTS				
P903	CABLE ASSY	-	R31Y16B29	-
28E25	SNAKE LUG	-	VJR-3	-
1W 3	WIRE	015Y160B25MFMF	-	015Y160B25MFMF
EXPLODED VIEW				
1M 1	FRONT PANEL R	N31148-1	N31148-1	N31159-1
1M 2	FRONT PANEL L	N45856-1	N45856-1	N45869-1
1M 3	HANDLE	N45858-BK1	N45858-BK1	-
1M 5	FRONT BASE	N10587-1	N10587-1	N10587-2
1M 6	HANDLE SPACER	N45846	N45846	-
1M26	REAR PANEL	N21861-1A	N21861-1A	N21861-2A
2M20	INNER CARTON	N21867-1	N21867-1	N21867-2
2M30	LABEL, UL (VIDEO)	N45914	-	N45914
4M25	SCREW-SP ASS, P HEAD B	SS312+40X14-B	-	SS312+40X14-B

## Capacitors Description

### • Electrolytic

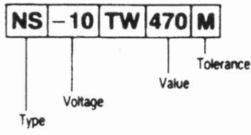

### • Mylar - Styrol

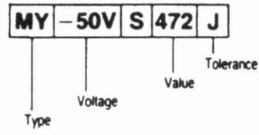

### • Ceramic

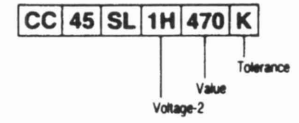
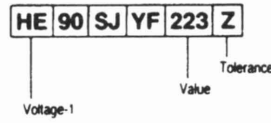

### • Electrolytic

Type	Voltage	Value	Tolerance
LL: Low Leak	-10: 10V	R47: 0.47 $\mu$ F	K: $\pm$ 10%
NP: Non-Pole	-50: 50V	4R7: 4.7 $\mu$ F	M: $\pm$ 20%
NS: Standard	6R3: 6.3V	470: 47 $\mu$ F	
		471: 470 $\mu$ F	
		472: 4700 $\mu$ F	

### • Mylar - Styrol

Type	Voltage	Value	Tolerance
MY: Mylar	-25V: 25V	4R7: 4.7pF	G: $\pm$ 2%
ST: Styrol	125V: 125V	470: 47pF	J: $\pm$ 5%
	-63T: 63V	471: 470pF	K: $\pm$ 10%
		472: 4700pF	M: $\pm$ 20%
		473: 0.047 $\mu$ F	
		474: 0.47 $\mu$ F	
		(1000pF=0.001 $\mu$ F)	

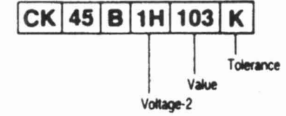

Voltage-1	Voltage-2	Value	Tolerance
HC: 25V	1E: 25V	4R7: 4.7pF	C: $\pm$ 0.25pF
HE: 50V	1H: 50V	470: 47pF	D: $\pm$ 0.5pF
H: 100V	2H: 500V	471: 470pF	F: $\pm$ 1pF
HK: 250V		472: 4700pF	J: $\pm$ 5%
HM: 500V		473: 0.047 $\mu$ F	K: $\pm$ 10%
		474: 0.47 $\mu$ F	M: $\pm$ 20%
		(1000pF=0.001 $\mu$ F)	Z: +80~-20%

## Resistors Description

### • Fixed

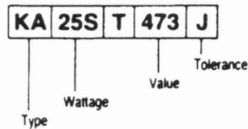

### • Semi-Variable

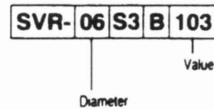

Type	Wattage	Value	Tolerance	Diameter
CE: Cement Case	-2W: 2W	R47: 0.47 $\Omega$	M: $\pm$ 20%	08: 8 $\phi$
FR: Flame Proof	10W: 10W	4R7: 4.7 $\Omega$	K: $\pm$ 10%	10: 10 $\phi$
KA: Carbon	16S: 1/6W	470: 47 $\Omega$	J: $\pm$ 5%	06: 6 $\phi$
MF: Metal Film	20S: 1/5W	471: 470 $\Omega$	G: $\pm$ 2%	
RF: Fusible	25S: 1/4W	472: 4.7k $\Omega$	F: $\pm$ 1%	
SA: Metal Oxide	50S: 1/2W	473: 47k $\Omega$	D: $\pm$ 0.5%	
	50X: 1/2W	474: 470k $\Omega$		
	S3W: 3W	475: 4.7M $\Omega$		

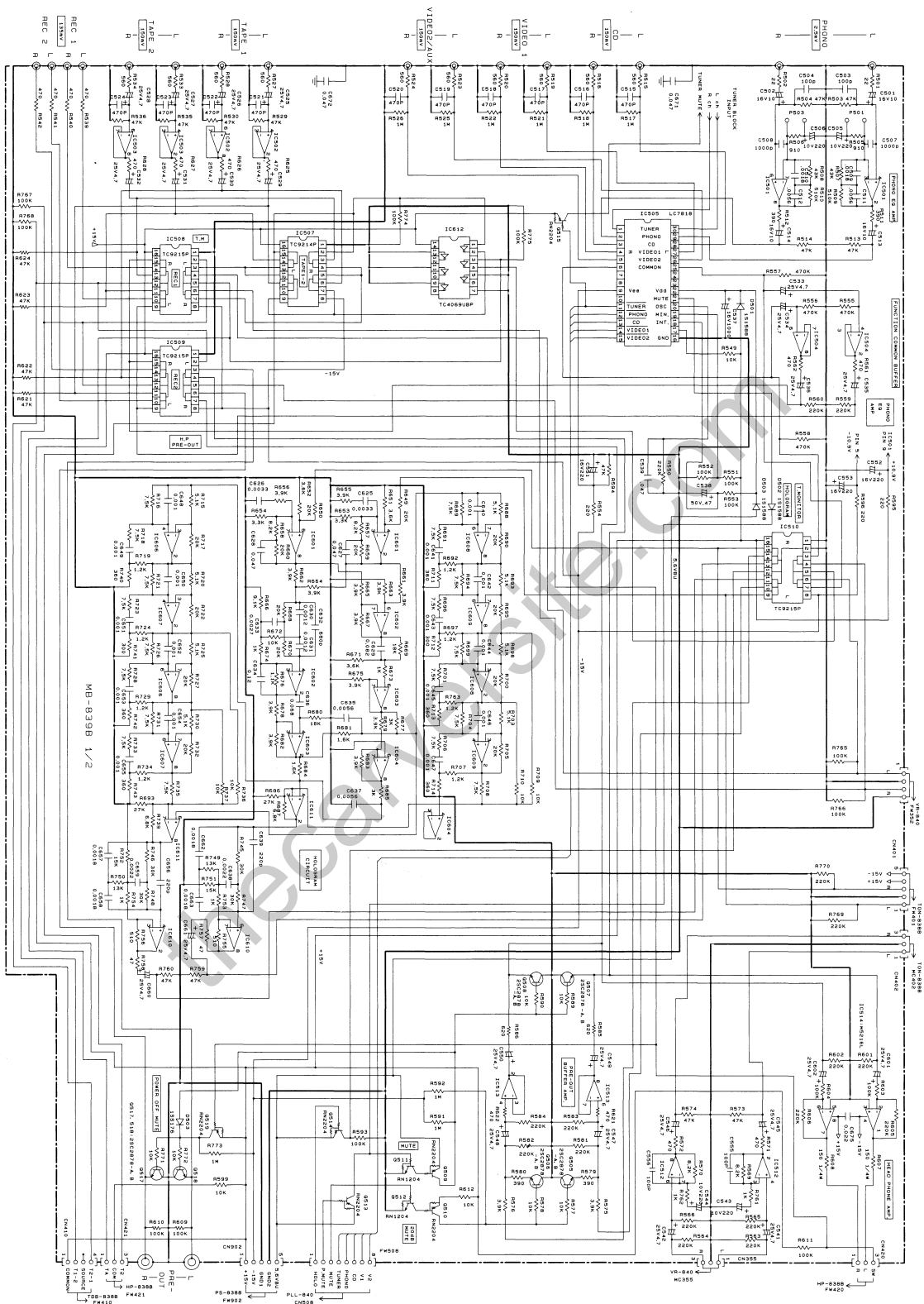



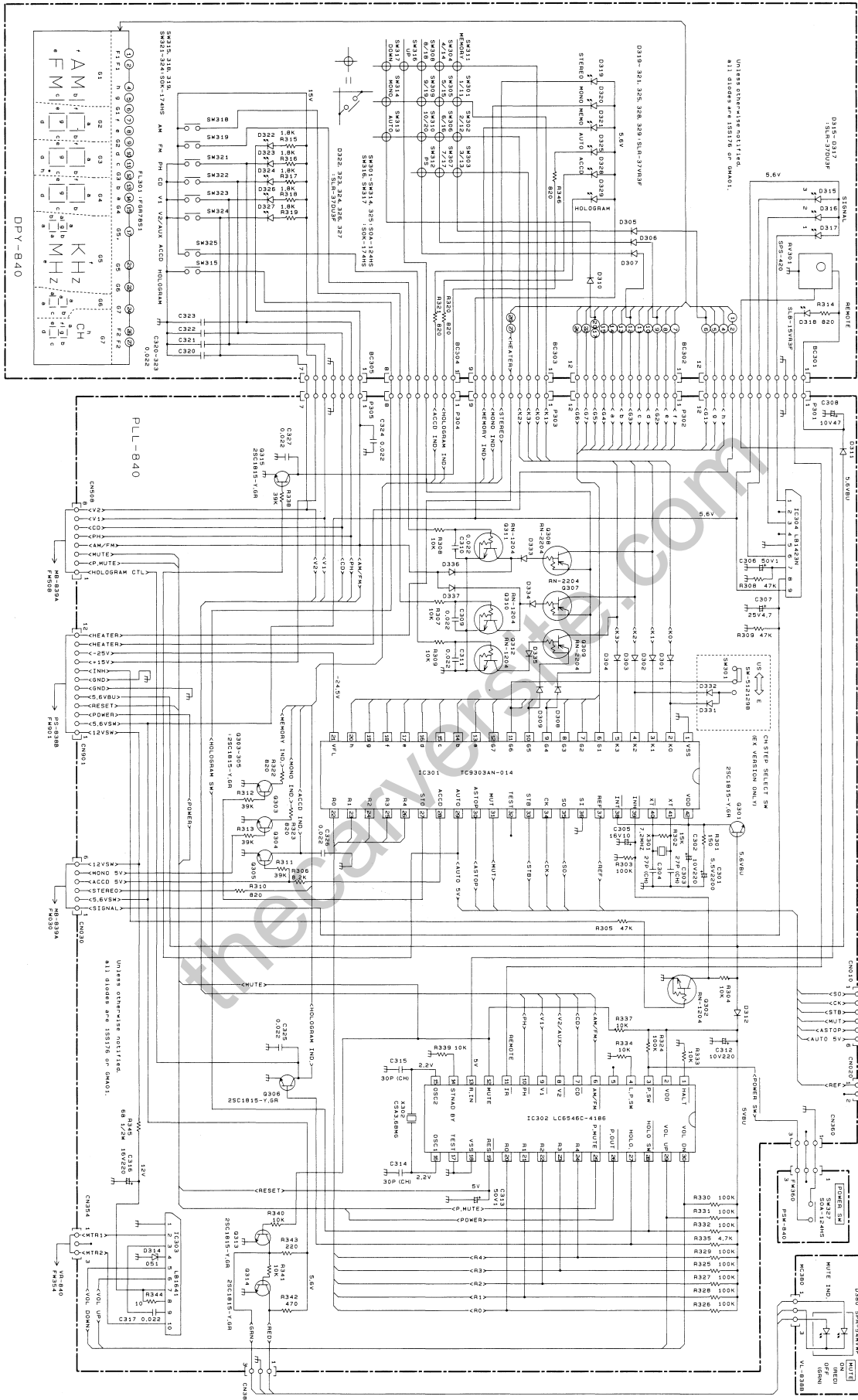

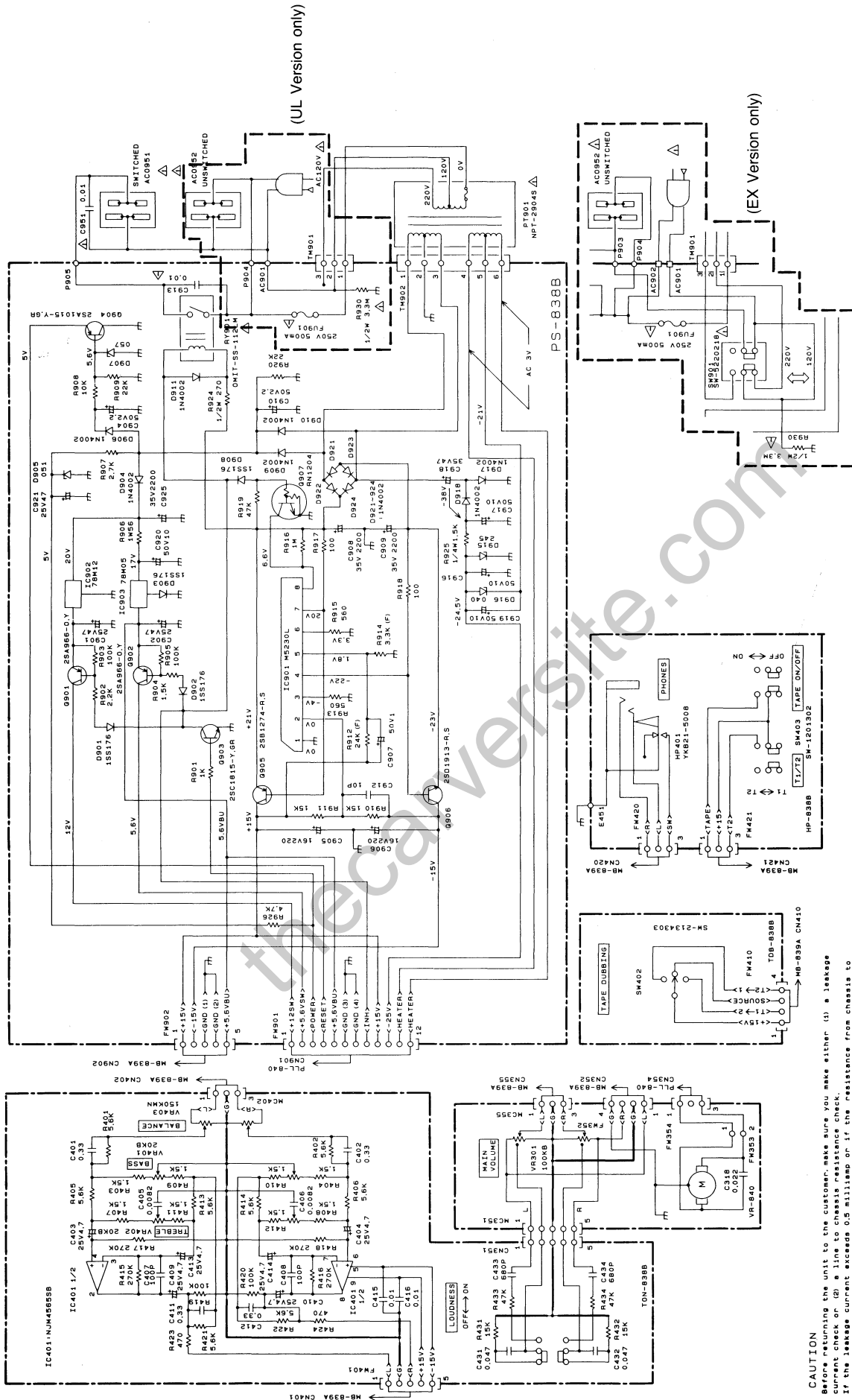

**CAUTION**  
 Before returning the unit to the customer, make sure you make either (1) a leakage current check or (2) a line to chassis resistance check.  
 If the leakage current exceeds 0.5 milliamperes or if the resistance from chassis to either side of the power cord is less than 500k ohms, the unit is defective.  
 WARNING: DO NOT return the unit to the customer until the problem is located and corrected.

**NOTES**  
 1. All resistors are 1/4 watt or 1/6 watt unless marked otherwise.  
 2. All capacitors are 50V unless marked otherwise.  
 3. Each DC voltage above the nominal values in volts no input signal.  
 4.  $\Delta$  is Safety Part. Use only replacement parts recommended by the manufacturer.

**CAUTION**  
 THOSE FUSES WITH MARKS  $\Delta$  ARE FAST-BLOW TYPE.  
 REPLACE WITH SAME TYPE 500mA 250V FUSE.  
**ATTENTION**  
 LES FUSIBLES MARQUÉS  $\Delta$  SONT DE TYPE A FUSION RAPIDE.  
 UTILISER UN FUSIBLE DE RECHANGE DE MEME TYPE DE 500mA 250V.

thecarversite.com

Copyright 1991 CARVER CORPORATION  
ALL RIGHTS RESERVED

## CARVER CORPORATION SERVICE BULLETIN

Service Bulletin # <i>CT-6-1</i>	Model: CT-6	Serial nos. ALL	
REASON: Audible buzz when hologram is engaged.		Date: 4/4/91	

DELETE QTY.	DESCRIPTION	ADD QTY.	DESCRIPTION
		2	100pF disc capacitor p/n 201-00012-00

### PROCEDURE

1. Remove top cover of CT-6. Locate IC514 and connector CN420 near left rear of main board.
2. Verify presence of high frequency oscillation at L & R pins of CN420. Use 50MHz scope and X10 probe.
3. Install 100pF disc caps between jumper J183 and R607, R608 (see drawing below).
4. Confirm that HF oscillation has been eliminated.

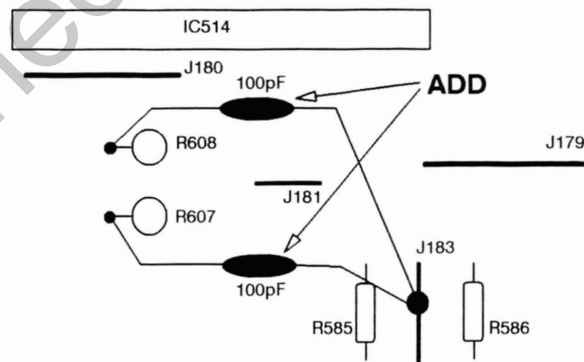

Service approval

Engineering approval

# CARVER CORPORATION SERVICE BULLETIN

Service Bulletin # CT-6-2

Model: CT-6 / PSC-60

Serial Nos. As Needed

REASON: To reduce overall gain for better control of volume when used with a high gain amplifier.

Date: 4/23/93

**DELETE**

Qty 2    620 ohm 1/8W CF Res    R585/R586  
P/N KA16ST621J

Qty 2    100K 1/8W CF Resistor    R609/R610  
P/N KA16ST104J

**ADD**

Qty 2    10K 1/8W CF Resistor    R585/R586  
P/N 260-50103-03

Qty 2    4.7K 1/8W CF Resistor    R609/R610  
P/N 260-50472-03A

## PROCEDURE

Performing this procedure will reduce the overall gain of the preamplifier by 10dB. It does not affect the Tape Outputs.

1. Turn power switch off and remove plug from AC outlet.
2. Remove top cover by removing 9 screw (3 from top, 2 from each side, 2 from back).
3. Remove Main PCB from chassis:
  - a) Remove 6 screws from rear panel securing RCA connectors to chassis.
  - b) Remove 2 screws from rear panel providing chassis to PCB ground connection.
  - c) Remove 2 screws from rear panel securing antenna inputs to chassis.
  - d) Release 6 nylon standoffs securing Main PCB to chassis.
  - e) Pull Main PCB toward front of unit until connecting jacks clear the rear panel. Lift up on back edge of PCB.
  - f) Flip Main PCB over towards front of unit, exposing solder side of board.
4. Remove and replace R585, R586, R609, R610 (see page 2 for part locations).

	<u>Old Value</u>	<u>New Value</u>
R585	620 ohms	10K
R586	620 ohms	10k
R609	100K	4.7K
R610	100K	4.7K

5. Reassemble unit by reversing above procedure.
6. Verify correct operation of unit.

Service Approval



Engineering Approval

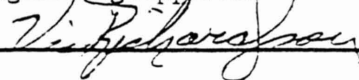

4-23-93

# CARVER CORPORATION SERVICE BULLETIN

Service Bulletin # CT-6-2

Model: CT-6

Serial Nos. As Needed

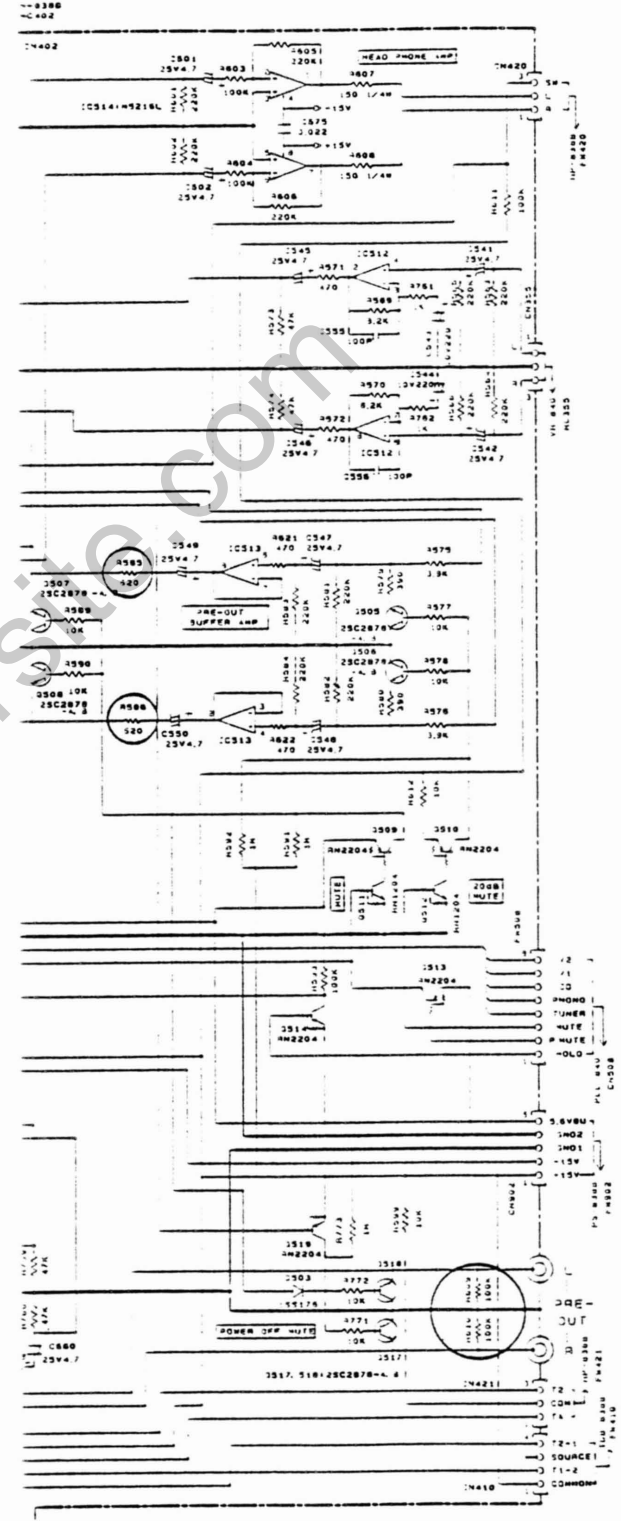
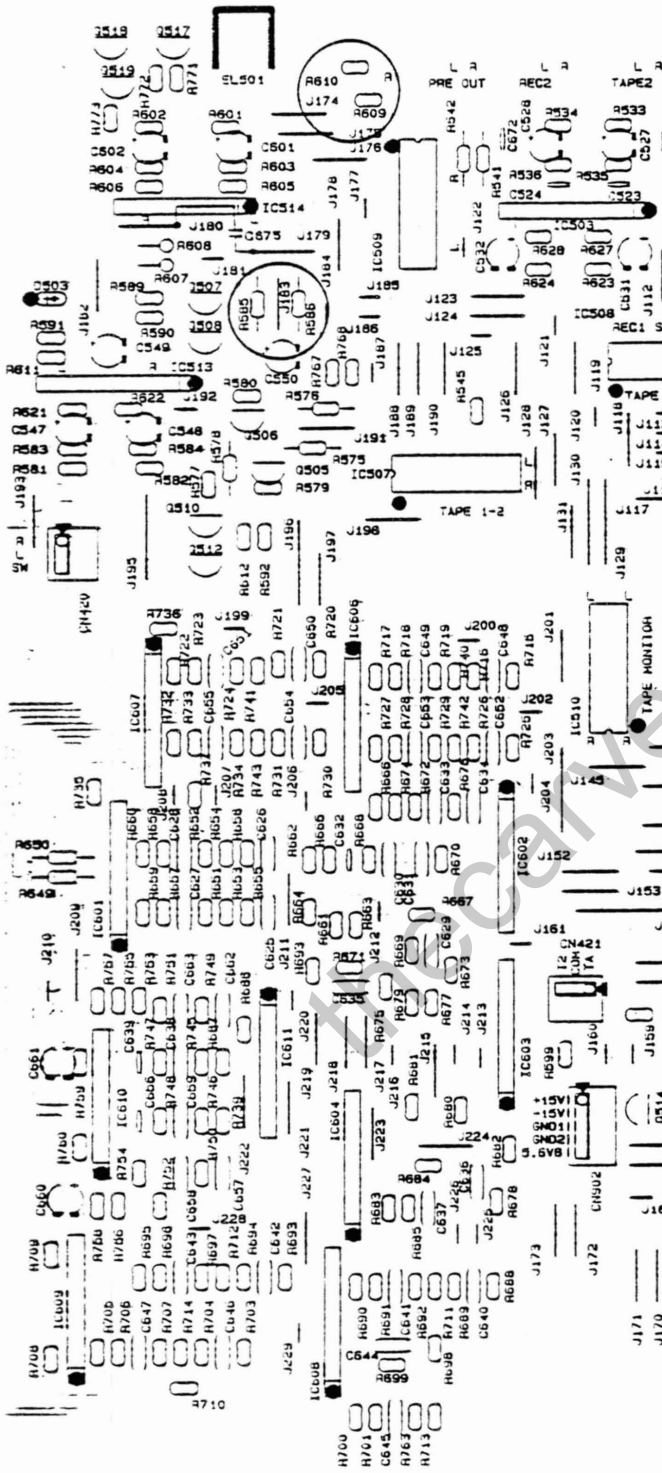

MB-839B Amp & Tuner P.C. Board



