

thecarversite.com

This manual is either an original scan from tech's who worked at Carver corp, donated by forum members, or both. These manuals are NOT intended for re-sale. If you purchased a 'Carver Manuals' disc on ebay or another auction site, and it has this material on it, you were ripped off!

Please report any resale of this material to us at thecarversite.com

thecarversite.com

OWNER'S MANUAL



Magnetic Field Power Amplifier
MODEL M-4.0t

Silver Seven Vacuum Tube
Transfer Function

CARVER

Powerful · Musical · Accurate

Table of Contents

| | |
|---|-----------|
| Safety Instructions | 4 |
| Introduction | 6 |
| 1 | |
| Prior to Installation | 7 |
| <i>Unpacking Your Amplifier</i> | |
| <i>A Definition of the M-4.0t Amplifier</i> | |
| <i>Placement of Your Amplifier</i> | |
| 2 | |
| Front Panel | 9 |
| <i>Operation</i> | |
| <i>Front Panel Display</i> | |
| 3 | |
| Rear Panel and Connections | 11 |
| <i>Rear Panel</i> | |
| <i>Loudspeaker Connections</i> | |
| 4 | |
| Features of Your M-4.0t Amplifier | 14 |
| <i>Magnetic Field Theory</i> | |
| <i>Amplifier Protection</i> | |
| <i>Speaker Protection</i> | |
| <i>Silver Seven Vacuum Tube Transfer Function</i> | |
| 5 | |
| Technical Information and Service Assistance | 18 |
| <i>Troubleshooting Guide</i> | |
| <i>Care of Your Model M-4.0t Amplifier</i> | |
| <i>Specifications</i> | |
| <i>Service Assistance</i> | |

Prior to Installation

NOTE: Do not connect the M-4.0t to AC power until all signal connections have been made and the installation is complete.

Unpacking Your Amplifier

Make a note of the serial number which is located on the back of your Amplifier. Record it in the space provided for convenient reference. You will need to refer to this number if you need service or if your unit is stolen.

Model M-4.0t

Serial number _____

Purchased at _____

Date _____

Please save the box, as well as all of the internal packing materials!

This container is the best way to store and move your new Amplifier. If your Amplifier should need repair, the original container is ideal for shipping to a CARVER Service Center.

Upon opening the box, please check for any visible sign of damage that does not appear on the outside of the box. If you do encounter what appears to be concealed damage, please consult your Dealer before proceeding to further unpack the unit.

If no damage is found, gently lift out the unit by grasping the handles. After lifting the Amplifier out of the box, gently lift first one side, then the other and remove the molded side packing material.

A Definition of the M-4.0t Amplifier

The CARVER M-4.0t is a stereo Magnetic Field Power Amplifier which incorporates CARVER's patented technology. This technology is utilized to create a powerful, highly efficient amplifier. Above all, the M-4.0t duplicates with extreme accuracy, the sonically pure characteristics of the Silver Seven Vacuum Tube Reference Amplifier.

NOTE: Please read the Owner's Manual and properly make all connections **BEFORE** you apply power to your Amplifier.

Placement of Your Amplifier

The M-4.0t is convection cooled and requires clearance for air to reach the ventilation slots on the top, bottom, and sides of the unit.

Do NOT place the amplifier on deep-pile carpeting or any similarly resilient surface that

might tend to block its ventilation slots from air circulation.

The M-4.0t can be placed in an equipment rack which has adequate ventilation. The other components in the rack should have adequate shielding to prevent picking up hum.

thecarversite.com

Front Panel

Figure 1 Front Panel

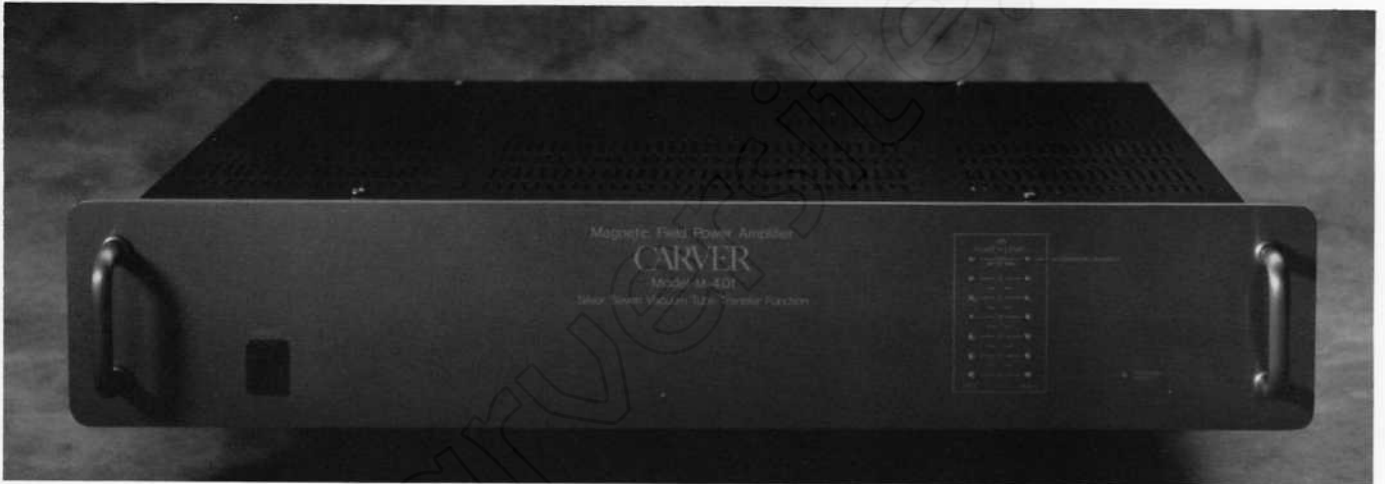

Operation

The CARVER M-4.0t has one control, the POWER switch, located in the lower left-hand corner of the front panel. We recommend that the unit NOT be switched ON or OFF with loud music playing. The POWER switch may be left in the ON position when the power line cord is connected to a SWITCHED OUTLET if available on the rear panel of your preamplifier. The M-4.0t is designed to be connected to the convenience outlet on your preamplifier or

directly to a wall outlet and controlled by the POWER switch provided on the front panel.

The minimum rating of the accessory outlet should be 500 W. Once properly connected to your system, the M-4.0t is ready for operation.

Front Panel Display

POWER LEVEL METERS

There are 15 light-emitting diodes (LEDs) on the

M-4.0t front panel. The two columns of seven LEDs monitor the output of the right and left channels. The bottom or #1 LEDs are power indicators which are lit when the amplifier is ready for operation. The #2—#6 LEDs indicate the power level, and have a 1 millisecond attack and a 500 millisecond decay. The #7 LEDs indicate clipping.

If, under normal operation, the top two HEADROOM EXHAUSTED LEDs blink, it means the amplifier is reaching its maximum output. It is acceptable for the LEDs to blink occasionally although you may hear increased distortion due to clipping.

OVERLOAD PROTECT

The amber OVERLOAD PROTECT LED indicates a fault condition that is either internal or external to the amplifier. If an external fault condition such as shorted speaker wires or a preamplifier problem should occur, the OVERLOAD PROTECT LED will cycle on every few seconds until the fault condition is corrected. When an internal fault condition occurs, the LED glows dimly.

NOTE: When the unit is first switched ON, the inputs will be muted for about four seconds to allow the amplifier to stabilize.

thecarversite.com

Rear Panel and Connections

Figure 2 Rear Panel



Rear Panel

Refer to Figure 3 and 4 for connection diagrams.

NOTE: Make sure the power cord of the unit is disconnected, before making any signal connections.

LEFT INPUT RIGHT INPUT

Use standard audio cables to connect the RIGHT and LEFT INPUTS on the rear panel of the M-4.0t to the appropriate OUTPUTS of the preamplifier. Refer to your preamplifier Owner's Manual.

Loudspeaker Connections

NOTE: The output of M-4.0t can develop **HAZARDOUS** voltages. Care should be used in connecting the speakers in order to prevent electric shock or damage to the amplifier. It is important that **NO** adjustment or alteration of speaker wiring is made when the unit is switched ON.

There are many excellent brands of speaker cables available from your audio Dealer. Ordinary lamp cord (zip cord), available in hardware stores in bulk, is also suitable for speaker cables. The usual gauge is #18, but for cable runs of 30 feet or more we recommend

Figure 3 Connections For Stereo Operation

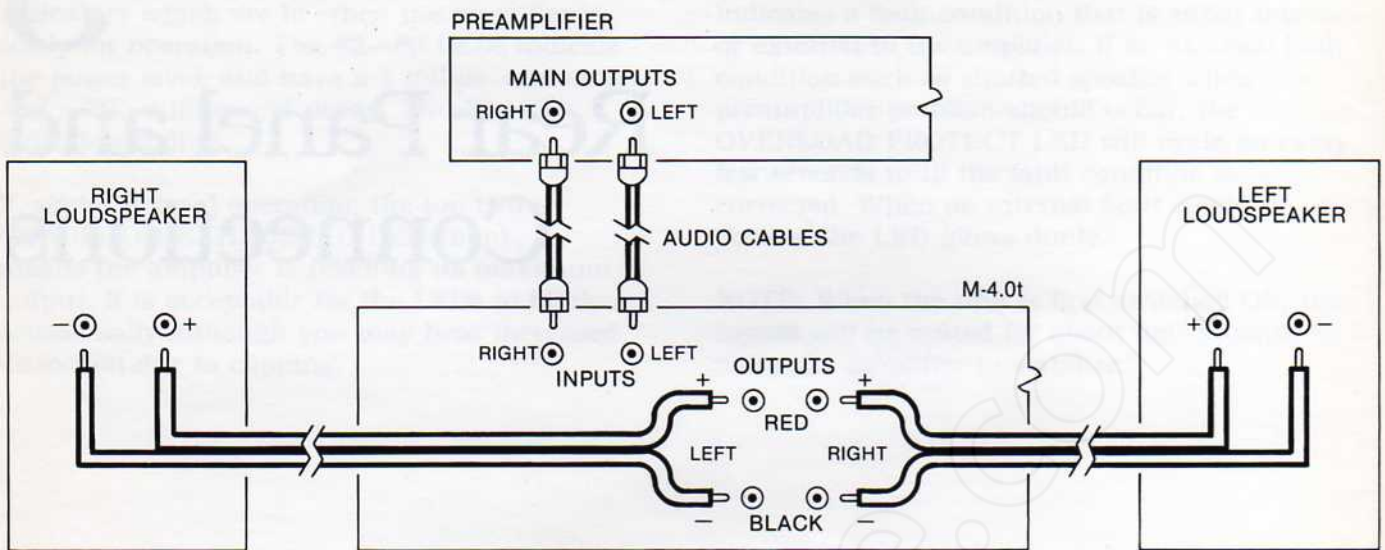

the heavier #16 gauge. If heavier wire is used, it is important that it be able to fit inside of the plastic cap on the binding post without stray wires.

RIGHT SPEAKER LEFT SPEAKER (+) (-)

- 1 The speaker wire should be prepared by stripping 1/2" of insulation from the end of the cable. Avoid nicking or damaging the conductor.
- 2 Twist the strands of wire together so that all the strands will fit inside the insulating cap of the binding post.
- 3 Follow the diagram on the rear panel of the unit matching polarities positive (+) and negative (-). Unscrew the binding post cap and insert the wire in the slot so that no bare wire will be showing when the cap is tightened.
- 4 Tighten the cap securely. Check to make sure that all strands of wire are inside the connection.

Loudspeakers must be connected with consistent polarity for correct phasing between them. Incorrect phasing will do no physical harm, but bass response will be diminished. Be sure that both speakers are connected in the

same way; positive (+) speaker terminal to positive (+) amplifier terminal, and negative speaker terminal (-) to negative (-) amplifier terminal.

Mono Connection

The M-4.0t can be used as an immensely powerful single channel amplifier without use of any special bridging adapter. Refer to the Rear Panel illustration, Figure 4. Connect from a Mono source the LEFT and RIGHT input jacks on the Amplifier with a "Y" adapter, the Mono source being either the LEFT or RIGHT output as shown or from a sub-woofer crossover. Push the Bridging switch to the recessed position. Having the switch recessed, avoids the switch being pushed inadvertently. The speaker leads must be connected to the red terminals only. The bottom black terminals remain unconnected. The (+) speaker wire connects to the red RIGHT SPEAKER binding post. The (-) speaker wire connects to the red LEFT SPEAKER binding post. The resulting output power is 1000 watts RMS into 8 ohms with no more than 0.5% THD.

FUSE

The FUSE value and type allows the amplifier to track the most powerful musical waveforms without compromising amplifier protection.

Do NOT increase the fuse value under any circumstance. Replace with original value and type only.

Loudspeaker Load Impedances

The M-4.0t is recommended for driving loudspeaker impedances between 2 and 16 ohms. Loads in excess of 16 ohms will cause a reduction in output power. Loads of much less than 2 ohms may cause premature tripping of

protection circuits or cause the fuse to blow. **Do NOT increase the fuse value under any circumstance. Replace with original value and type only.**

Additional pairs of loudspeakers may be connected to the amplifier in the same way as the first pair as long as the total nominal impedance is not less than 2 ohms. Switching between speakers will require an outboard speaker switching accessory.

Figure 4 Connections for Mono Operation

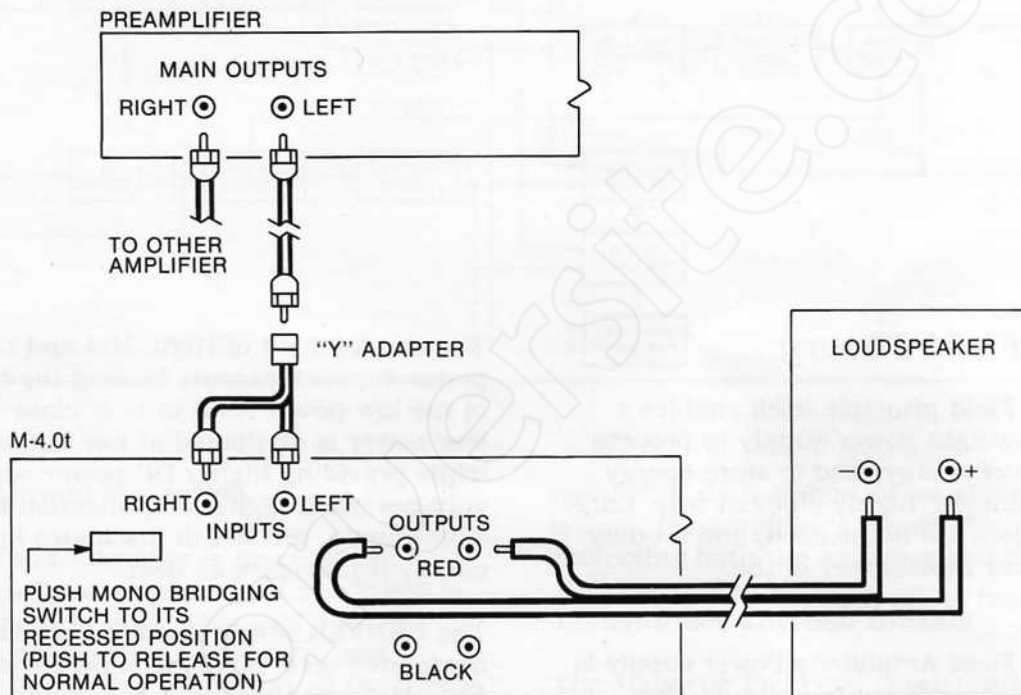

4

Features of Your M-4.0t Amplifier

Magnetic Field Theory

The Magnetic Field principle itself enables a compact, lightweight power supply to process large amounts of energy, and to store energy reserves in a unique, highly efficient way. Large supply capacitors are not needed, and a bulky expensive power transformer of the conventional sort is not required.

The Magnetic Field Amplifier's Power supply is governed by electronic control circuits that directly respond to the moment-to-moment power requirements of the audio sections.

Referring to the Block Diagram Figure 5, the AC power control circuitry controls the amount of power the Magnetic Field coil must store and transfer. The AC power control receives its instructions from the power demand sense circuitry which are transferred to the primary via the optocoupler.

For low power demands, conduction begins near the minimum voltage points for the AC line signal, and is relatively brief in duration. As more drive becomes needed, conduction begins earlier and lasts longer.

The employment of High, Mid and Low DC power supplies permits biasing the output stage of the low power AMP to near class "A". Much less power is dissipated at low output levels while providing higher DC power supply voltages when higher amplification is required. Accordingly, the M-4.0t dissipates little of the energy it processes as heat.

The CARVER M-4.0t Amplifier's power supply is modulated on a signal-demand basis. It uses Low, Mid and High DC power supply voltages combined with Low, Mid and High power amplification stages to increase your Amplifier's power from a 35 watt amplifier into a 400 plus watt-per-channel amplifier. The result is high efficiency, with large output capability.

Amplifier Protection

This unit incorporates a main fuse along with specifically designed protection circuits to protect the amplifier and loudspeakers. If at any time your Amplifier does not function, please refer to the Troubleshooting Guide of this manual to determine if the amplifier is in a protection mode.

Figure 5 M-4.0t Block Diagram

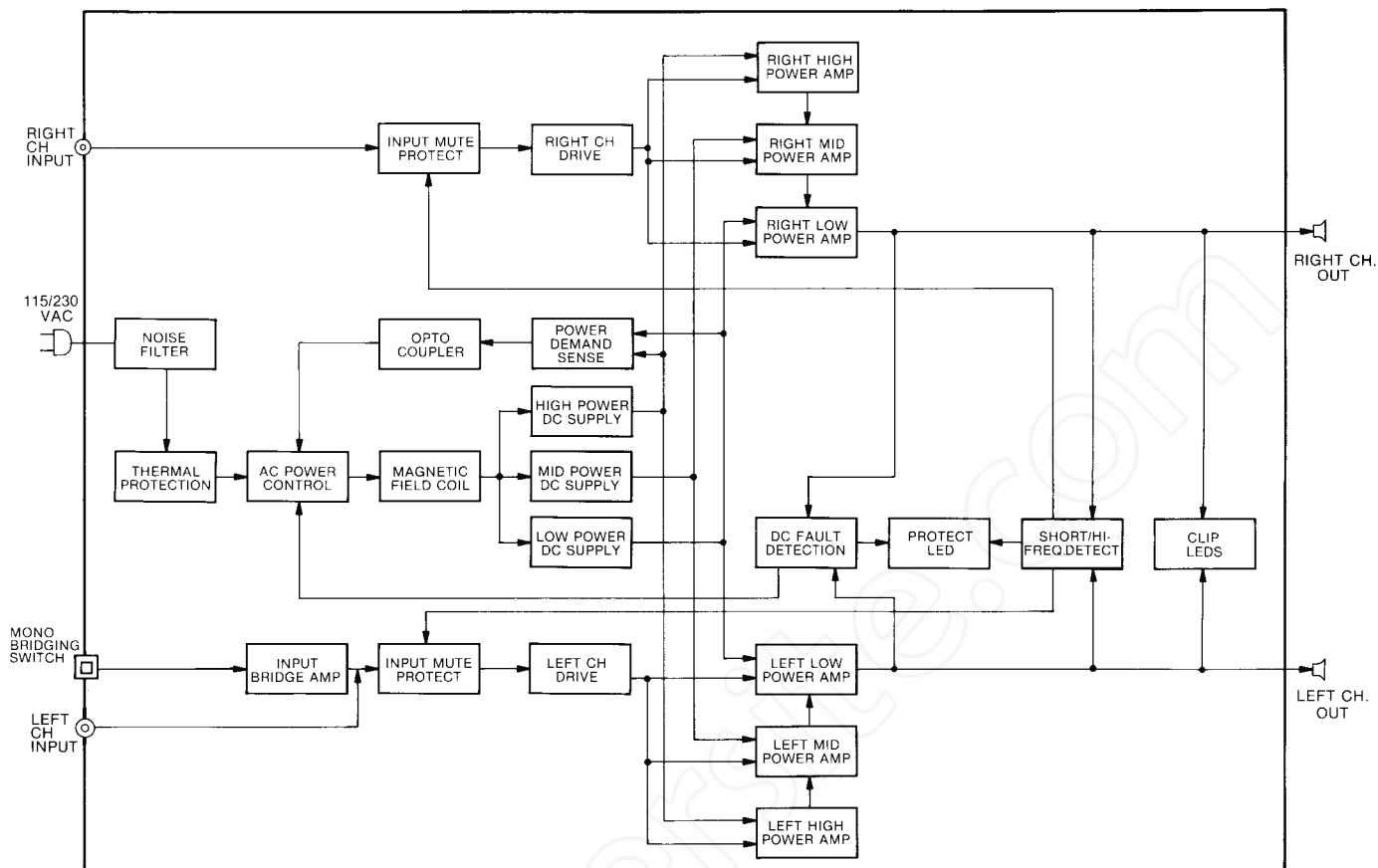

Amplifier Thermal Protection

A Magnetic Field Amplifier is more efficient than a conventional amplifier and much less is required of the heat sink. This unit employs heat sinks to efficiently dissipate the heat generated by the power transistors. If the unit is used in a poorly ventilated location or in a position exposed to direct sunlight and high power output, the heat may not be sufficiently dissipated and the temperature may rise abnormally. In cases like this, the protection circuit will be activated if the temperature of the heat sinks rises to more than 100° C.

Overcurrent Protection Circuit

Excessive current is limited through the Amplifier's output transistors when the speaker wires at either the Amplifier or speaker terminals are shorted. Excessive current is also limited into abnormal loads, for example, a damaged speaker or too many speakers wired in

parallel. If such a short or an abnormal load occurs, the amplifier's inputs are muted, protecting both the amplifier and the speakers.

Transformer Thermal Breaker

The Magnetic Field coil is internally protected by a 150° C thermal cut-out switch. This switch protects the transformer from damage due to overheating under abnormal conditions.

Major Fault Protection

The MDA 12 slo-blo line fuse will protect the unit from damage should a major fault condition occur.

Speaker Protection

DC Detection Circuit

If one of the components inside the amplifier should malfunction and cause the amplifier to

produce a significant DC voltage, the amplifier will power down to a safe output level. This circuit is activated when a DC voltage of more than ± 4.5 V is detected.

Excessive High Frequency Output

If excessive non-musical/high frequency signals occur, the Amplifier will mute the inputs thus protecting both the speakers and the Amplifier.

Additional Speaker Protection

We recommend fusing all loudspeakers according to their manufacturer's recommendation.

If you are using speakers that do not have a sufficient power rating and are not capable of handling the maximum output power of the M-4.0t, then speaker fusing is advisable. Use the fuse value recommended by the manufacturer.

Silver Seven Vacuum Tube Transfer Function

Now that you know the features and performance of your new M-4.0t, we want you to meet its inspiration — The Silver Seven Vacuum Tube Mono Power Amplifier. Destined to redefine ultra-high end values forever, the Silver Seven Amplifier is truly a money-is-no-object design. The sound of the Silver Seven Amplifier is musical, effortless — the sound stage created is immense.

The Silver Seven Amplifier employs classic, fully-balanced circuit topology and the finest components in existence.

- A-450 Ultra-linear output transformers with oxygen-free primary leads and pure silver secondaries.
- Wonder Cap capacitors throughout.
- Interconnects are Van den Hul Silver.
- Wonder solder throughout.
- Gold input connectors and high current gold output connectors.

Its polished granite anti-vibration base floats on four Simm's vibration dampers. The separate power supply's transformer end-bells are machined from a solid block of high density aluminum.

Capable of an astonishing 390 joules energy storage, the Silver Seven Amplifier delivers a conservatively rated 375 watts into 8 ohms from 20 Hz to 20 kHz with no more than 0.5% distortion.

It can pump out 475 watts over a power bandwidth of 18 Hz to 40 kHz. On the 1-ohm tap, peak current is in excess of 35 amps!

What does this have to do with the M-4.0t?

Everything.

Sonically, the M-4.0t Amplifier is everything the extravagant Silver Seven Amplifier is and here's why.

Figure 6 Silver Seven



The secret lies in Bob Carver's talent to perfectly re-create the Transfer Function of an amplifier. That is, the amplifier's ability to re-create the relationship between its input and output signals. Every amplifier design has a unique and distinctive voice so extraordinarily subtle it can be recognized by only the most sophisticated and highly sensitive ears. That voice is the amplifier's transfer function. Bob Carver has perfected the art of measuring the Transfer Function and duplicating it in a completely different amplifier design. He endowed his solid state M-1.0t with the Transfer Functions of a set of \$5000 esoteric tube amps. What began as a challenge posed to Bob Carver by a stereo magazine several years ago, ended with creating a reference standard amplifier design.

Carver achieved the duplication of the Silver Seven Amplifier's Transfer Function for the M-4.0t.

And that is why we can say: the M-4.0t has direct lineage from the finest power amplifier ever built. The M-4.0t boasts a rated output of 375 watts per channel into 8 ohms with less than 0.5% THD. It delivers 1000 watts continuous sine wave output at 8 ohms in bridging mode. The M-4.0t also features intricate safeguards for your speakers and amplifier. As you can see, the real winner of the challenge is you.

5

Technical Information and Service Assistance

Troubleshooting Guide

WARNING: NEVER replace or check a fuse while the unit is plugged into an AC outlet. The Amplifier must be turned OFF for at least one minute before any AUDIO cables may be disconnected.

| Problem | Probable Cause | Solution |
|---|--|---|
| Upon power up no LEDs lit | Unit unplugged. POWER switch OFF. Fuse blown. | Check power cord. Replace fuse. If fuse blows again upon power up, the Amplifier will require servicing. |
| Upon power up, LEDs DIM or OFF AND/OR unit makes buzzing sound. | Unit defective | Amplifier will require servicing |
| Unit runs initially No LEDs lit; no sound | Heatsink thermal switch; Transformer Thermal Switch Fuse is blown. | Improve top cover ventilation clearances. Allow 5-15 minutes to cool. Replace fuse. If fuse immediately blows after replacing when the unit is switched ON, then the unit will require servicing. |
| PROTECT LED comes on when VOLUME turned up; no sound from both speakers | Shorted speaker. Damaged speaker. | Check speaker wires. Disconnect all speakers at amplifier, then check OVERLOAD PROTECT LED with VOLUME up. If OVERLOAD PROTECT LED goes out, this either means too many speakers connected, or possible damaged speaker(s). |

| Problem | Probable Cause | Solution |
|---|-------------------------------------|---|
| No sound BOTH channels | Speaker fuses | Replace fuses. |
| OVERLOAD PROTECT LED OFF display (red) LEDs ON | Defective AUDIO cables | Replace cables. |
| | Preamp source Selector (Mode) | Check Preamp Selector (Mode). |
| | Preamp/Amp defective | Substitute a different preamp or amp to determine which may be at fault. Refer to CARVER Service Center. |
| No sound in ONE channel OR ONE channel has distorted sound | Preamp BALANCE Control | Check BALANCE control for center position. |
| | Disconnected speaker wire | Turn OFF unit. Check speaker wire connections at amplifier and speakers. Check speaker fuses. |
| | Defective amp or speaker | If swapping the AUDIO cables at the Amp inputs does not change which channel is defective, then the Amp may be defective if the speakers or speaker wires are OK. If defective channel swaps, then the problem is before the Amplifier. |
| | Defective audio cables | If swapping the AUDIO cables at the Preamplifier outputs does not change the defective channel, the problem is with the AUDIO cables. If the problem changes the defective channel, the problem is with either the Preamp, source equipment, (CD player, Tape deck, etc.) or Preamp input cables. Check preamp AUDIO input cables in the same manner as the Amplifier input cables to determine if the problem is before the Preamp. Determine distortion source by following the above procedure. |
| Noise from the right speaker | No input connections | NOTE: With inputs unconnected, the right channel will exhibit more noise than the left. This is normal. When the amplifier inputs are connected to the Preamp, the excessive noise will be eliminated. Because of the special termination of the Bridging Amp channel, the LEFT channel is quieter when not connected. |
| | Amplifier, cables or Preamp problem | Repeat above procedure for "No sound ONE channel" |

Care of Your Model M-4.0t Amplifier

Make every effort to keep your Amplifier away from high external temperatures, moisture, and airborne substances that can leave greasy deposits and dust. When panels and covers become dirty, they can be cleaned with a soft cloth slightly moistened with a diluted ammonia solution. Never use detergents, abrasives, or a wet cloth.

Never short circuit the output terminals of the Amplifier. When connecting the loudspeakers, avoid speaker wires touching at the terminals. Protect your Amplifier from moisture and excessive dust. Avoid dropping your Amplifier. Never replace the fuse with one other than the specified rating. If you suspect a problem, try troubleshooting first. Frequently, a problem lies elsewhere in the system or even in the connecting cables.

Specifications

| | |
|--------------------|--|
| Power Output: | 375 watts per channel into 8 ohms from 20 Hz to 20 kHz with no more than 0.5% THD |
| | 500 watts per channel into 4 ohms from 20 Hz to 20 kHz with no more than 0.5% THD |
| Mono Bridged: | 1000 watts per channel into 8 ohms from 20 Hz to 20 kHz with no more than 0.5% THD |
| Power at Clipping: | 450 watts per channel into 8 ohms at 1 kHz, both channels. |
| | 550 watts per channel into 8 ohms at 1 kHz, one channel only. |

Frequency Response: $\pm .5$ dB 20 Hz to 20 kHz

IM Distortion: Less than 0.15%

Noise: 110 dB A-weighted referenced to rated power

Input Impedance: 115 K ohms

Sensitivity: 1.7 V RMS for rated 8 ohm power

Gain: 30 dB

Display: Independent Clipping Indicators
Power on indicators
Power Level indicators

Size: H 3.5"
W 19"
D 10.5"

Weight: 23 lbs

TEST NOTE: Accurate measurement of the M-4.0t depends on a sufficiently "stiff" AC supply. The 60 Hz AC line distortion must be below IHF specification.

Service Assistance

NOTE: Fill out and mail the **WARRANTY REGISTRATION CARD** which is enclosed in a separate envelope with the **CARVER LIMITED WARRANTY**.

If your CARVER product should require service, we suggest you contact the Dealer from whom you purchased your unit. Should the Dealer be unable to take care of your needs, you may contact CARVER Customer Service Department by phoning (206) 775-6245, or by writing CARVER CORPORATION, Customer Service Department, P.O. Box 1237, Lynnwood, WA 98046. We will then direct you to one of our national network of factory trained and authorized Warranty Service Centers, or give you detailed instructions on returning the product to us for prompt appropriate action.

We suggest you read the **LIMITED WARRANTY** completely to fully understand what your warranty/service coverage is, and the duration.

You must promptly complete and return the
WARRANTY REGISTRATION CARD to validate
your LIMITED WARRANTY.

We wish you many hours of musical enjoyment.
If you should have questions or comments,
please write to:

CARVER CORPORATION
Customer Service Department
P.O. Box 1237
Lynnwood, WA 98046
(206) 775-6245

Ask your CARVER Dealer to show you the
CARVER family of stereo components for your
home audio reproduction. Selected CARVER
electronics that can accompany your M-4.0t ar

Preamplifier
Tuner
Speakers
Compact Disc Player

thecarversite.com

thecarversite.com

CARVER CORPORATION, P.O. Box 1237, Lynnwood, WA 98046