

thecarversite.com

This manual is either an original scan from tech's who worked at Carver corp, donated by forum members, or both. These manuals are NOT intended for re-sale. If you purchased a 'Carver Manuals' disc on ebay or another auction site, and it has this material on it, you were ripped off!

Please report any resale of this material to us at thecarversite.com

thecarversite.com

CARVER

TFM-25 and TFM-22 Owner's Manual
Simultaneous High Current/High Voltage
Magnetic Field Power Amplifiers

CARVER

ticular characteristic of the inductor, such as copper conductance.

This multi-layer inquest (with an almost infinite number of branches) continues until Bob has identified all those parameters which contribute to the amplifier's transfer function, and changed them to achieve his target null with the reference amplifier. In every case, changes made at global and local stages are referenced to the main Null test, time and time again.

The process at work. Another perspective is provided by the former editor of *Stereophile*, J. Gordon Holt, when Bob came to Santa Fe to perform a t-modification on a Carver design using a reference amplifier of the magazine's choice. "I had assumed that Bob would simply listen at length to our reference amplifier, make a measurement or two and then try various means to duplicate what he had heard and measured. His approach turned out to be much less scattershot than that.

"The hotel room was a shambles! Across one end was a long table buried in oscilloscopes, distortion analyzers, voltmeters, white noise generator, a half-dozen partially-drained Diet Coke cans and perhaps 50 feet of audio cables, test leads and clip-lead interconnects. The adjacent sofa and table were covered with countless little bags of capacitors and resistors, several schematic diagrams and sheets of paper crammed with arcane numbers and calculations".

What transfer function means to you. The TFM-22 and TFM-25 TRANSFER FUNCTION CALIBRATED power amplifier designs have been t-modified using Bob Carver's Null Test and the Silver Seven Vacuum Tube Monoblock design. Each model has gone through the tedious process described above, often extending to weeks of Bob's typical 48-hour marathon work sessions.

When considering the benefits of Transfer Function Calibration, it is important to understand the difference between total output power and sonic characteristics. The reference Silver Seven is rated 375 watts into 8 ohms, from 20-20kHz with no more than 0.5% total harmonic distortion, while the TFM-22/TFM-25 is rated at 225 watts over the same bandwidth and with the same THD figure.

Thus, we are not claiming that a TFM-22 is the exact equivalent of the Silver Seven (\$17,500 has to buy you *something extra!*). What you can be assured of is that the Carver Magnetic Field Power Amplifier you now own has a transfer function which closely resembles that of the Silver Seven. Signals entering them exit with the sonic characteristics which distinguish the Silver Seven benchmark design. That means (indulging in subjective audiophile adjectives for a moment) a warm, liquid, "tube" sound, free from harshness and metallic overtones. A detailed and open sound field, solid bass, rich, organic midrange and intricately detailed high end.

Enjoy!



The lightning flash with arrowhead symbol within an equilateral triangle is intended to alert the user to the presence of uninsulated "dangerous voltage" within the product's enclosure, that may be of sufficient magnitude to constitute a risk of electric shock to persons.



The exclamation point within an equilateral triangle is intended to alert the user of the presence of important operating and maintenance (servicing) instructions in the literature accompanying the appliance.

Safety Instructions

1. Read Instructions — All the safety and operation instructions should be read before the Carver Component is operated.
2. Retain Instructions — The safety and operating instructions should be kept for future reference.
3. Heed Warnings — All warnings on the Component and in these operating instructions should be followed.
4. Follow Instructions — All operating and other instructions should be followed.
5. Water and Moisture — The Component should not be used near water - for example, near a bathtub, washbowl, kitchen sink, laundry tub, in a wet basement, or near a swimming pool, etc.
6. Ventilation — The Component should be situated so that its location or position does not interfere with its proper ventilation. For example, the Component should not be situated on a bed, sofa, rug, or similar surface that may block any ventilation openings; or placed in a built-in installation such as a bookcase or cabinet that may impede the flow of air through ventilation openings.
7. Heat — The Component should be situated away from heat sources such as radiators, or other devices which produce heat.
8. Power Sources — The Component should be connected to a power supply only of the type described in these operation instructions or as marked on the Component.
9. Power Cord Protection — Power-supply cords should be routed so that they are not likely to be walked upon or pinched by items placed upon or against them, paying particular attention to cords at plugs, convenience receptacles, and the point where they exit the Component.
10. Cleaning — The Component should be cleaned only as recommended in this manual.
11. Non-use Periods — The power cord of the Component should be unplugged from the outlet when unused for a long period of time.
12. Object and Liquid Entry — Care should be taken so that objects do not fall into and liquids are not spilled into the inside of the Component.

13. Damage Requiring Service — The Component should be serviced only by qualified service personnel when:

- A. The power-supply cord or the plug has been damaged; or
- B. Objects have fallen, or liquid has spilled into the Component; or
- C. The Component has been exposed to rain; or
- D. The Component does not appear to operate normally or exhibits a marked change in performance; or
- E. The Component has been dropped, or its cabinet damaged.

14. Servicing — The user should not attempt to service the Component beyond those means described in this operating manual. All other servicing should be referred to qualified service personnel.

15. Power Lines - An outdoor antenna should be located away from power lines.

16. External Antennas - Section 810 of the National Electrical Code ANSI/NFPA No. 70-1984 provides information with respect to proper grounding of the mast and supporting structure, grounding of the lead-in wire to an antenna discharge unit, size of grounding conductors, location of antenna-discharge unit, connections to grounding electrodes, and requirements for the grounding electrode.

17. CAUTION – To prevent electric shock, do not use this polarized plug with an extension cord, receptacle or other outlet unless the blades can be fully inserted to prevent blade exposure.

PORTABLE CART WARNING



Carts and stands - The Component should be used only with a cart or stand that is recommended by the manufacturer. A Component and cart combination should be moved with care. Quick stops, excessive force, and uneven surfaces may cause the Component and cart combination to overturn.

ATTENTION – Pour prévenir les chocs électriques ne pas utiliser cette fiche polarisée avec un prolongateur, une prise de courant ou une autre sortie de courant, sauf si les lames peuvent être insérées à fond sans en laisser aucune partie à découvert.

18. Grounding or Polarization - Precautions should be taken so that the grounding or polarization means of the Component is not defeated.

19. Internal/External Voltage Selectors — Internal or external line voltage selector switches, if any, should only be reset and re-equipped with a proper plug for alternate voltage by a qualified service technician. See an Authorized Carver Dealer for more information.

20. Attachment Plugs for Alternate Line Voltage (Dual voltage models only)— See your Authorized Carver Dealer for information on the attachment plug for alternate voltage use. This pertains to dual-voltage units only.

This digital apparatus does not exceed the Class A/Class B (whichever is applicable) limits for radio noise emissions from digital apparatus as set out in the radio interference regulations of the Canadian Department of Communications.

Le présent appareil numérique n'émet pas de bruits radioélectriques dépassant les limites applicables aux appareils numériques de class A/de class B (selon le cas) prescrites dans le règlement sur le brouillage radioélectrique édicté par le ministère des communications du Canada.

WARNING – To reduce the risk of fire or electric shock, do not expose this appliance to rain or moisture.

FIGURE 75. 1
EXAMPLE OF ANTENNA GROUNDING AS PER
NATIONAL ELECTRICAL CODE

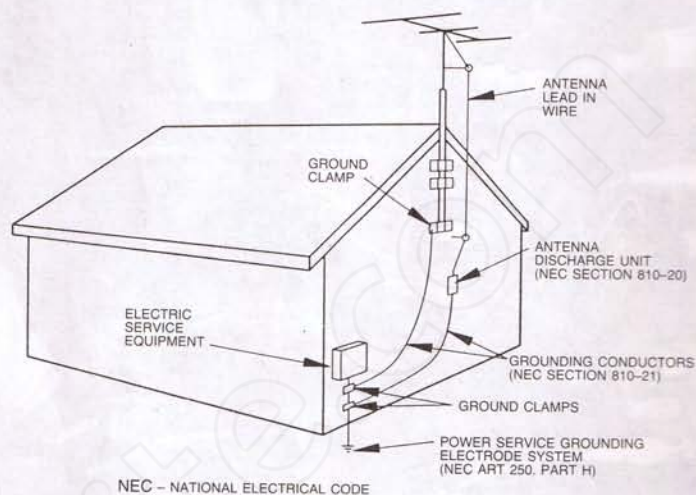

S2898A

Introduction

A Message from Bob Carver

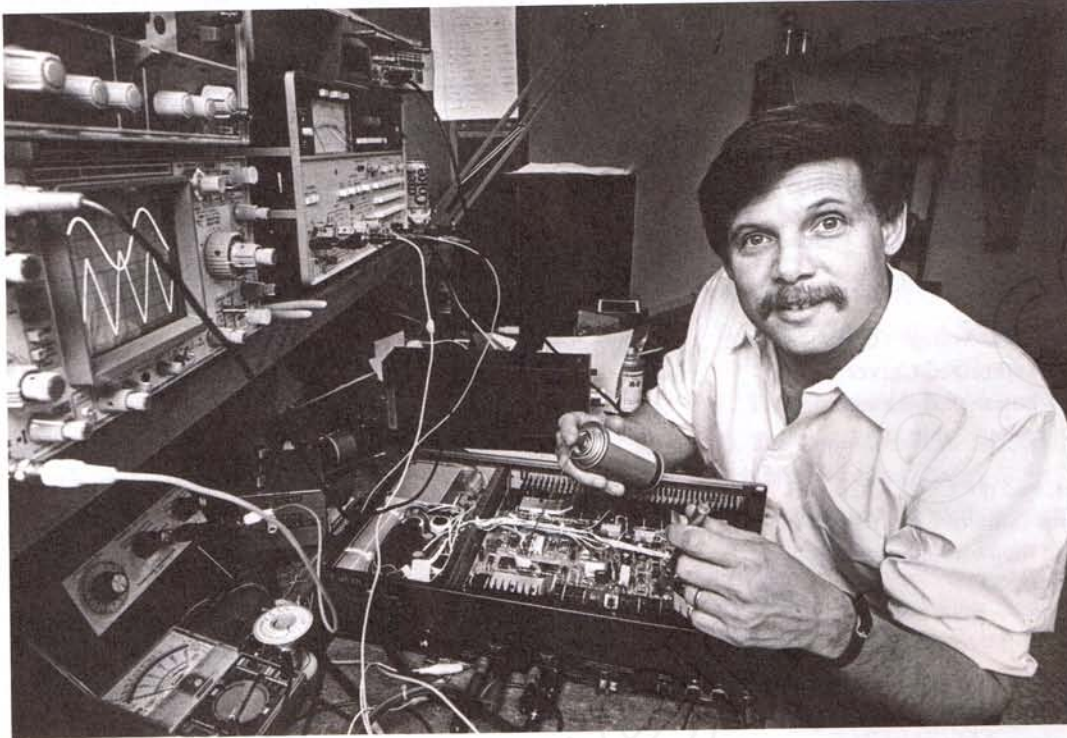

which make them capable of higher simultaneous current and voltage than any other designs in their price range. Judged against conventional amplifier standards, they are second to none;

their sound quality is smooth, sweet and absolutely dynamically accurate. They can deliver more than 225 watts RMS per channel into an 8 ohm loudspeaker with less than 0.5% THD and lots more into lower impedances. In addition, the closed-loop frequency response extends from below 10 Hz to beyond 100,000 Hz.

And Magnetic Field Amplifier technology yields even more performance advantages. Your TFM-22 or TFM-25 is remarkably efficient; considerably more efficient than conventional amplifiers. The Magnetic Field principle itself enables the power supply to process

large amounts of energy, store energy reserves in a unique, highly efficient way and directly respond to the moment-to-moment power requirements of today's demanding musical recordings.

I am proud to present to you the best in craftsmanship and design found in Carver electronics.

Robert W. Carver
President, Carver Corporation

Dear CARVER Customer,

Thank you for choosing a Carver power amplifier. We at Carver Corporation realize that there is an abundance of home electronics from which to choose, and that the differences between the various models are not always apparent at first glance. We strive to produce for you the finest in audio reproduction equipment. Our intent is to integrate the latest and best technology with the most competitive price possible.

Our TFM-25 and TFM-22 power amplifiers include Carver Magnetic Field Amplifier technology

Contents

<i>Introduction</i>	4
1. Prior to Installation	6
2. Setting Up the Amplifier	7
Definition of the TFM-25/TFM-22 Amplifier	7
Amplifier Placement	7
Front Panel	7
Rear Panel	8
Connections for Stereo Operation	9
Connections for Mono Operation	10
Loudspeaker Load Impedances	11
Speaker Protection	11
Multiple Speakers	11
3. Technical Information and Service Assistance	12
<i>Appendix. Magnetic Field Amplifier and Transfer Function Modification</i>	14

1. Prior to Installation

NOTE: Do not connect the TFM-22/TFM-25 to AC power until all signal connections have been made and the installation is complete.

Upon opening the box, please check for any visible sign of damage that does not appear on the outside of the box. If you do encounter what appears to be concealed damage, please consult your Dealer before proceeding to further unpack the unit.

If no damage is found, gently lift out the unit by grasping the handles. After lifting the Amplifier out of the box, gently lift first one side, then the other and remove the molded side packing material.

Please save the box, as well as all of the internal packing materials! This container is the best way to store and move your new Amplifier. If your Amplifier should need repair, the original container is ideal for shipping to a Carver Service Center.

Make a note of the serial number which is located on the back of your Amplifier. Record it in the space provided for convenient reference. You will need to refer to this number if you need service or if your unit is stolen.

Model: **TFM-22/TFM-25**

Serial number: _____

Purchased at: _____

Date: _____

Make sure to save your sales receipt. It is extremely important to establish the duration of your Limited Warranty and for insurance purposes.

Finally, take a moment to fill out and return the Warranty Card that came with the Amplifier and return it to Carver.

2. Setting up the Amplifier

A Definition of the TFM-25/TFM-22 Amplifier

The CARVER TFM-22 and TFM-25 are stereo Magnetic Field Power Amplifiers which incorporate CARVER's patented technology. The TFM-22 and TFM-25 are sonically identical. The only difference is the front panel metering. The TFM-25 employs analog power meters; the TFM-22 only has LED clipping meters.

All back panel connections are identical.

Above all, the TFM-25 and TFM-22 both replicate with extreme accuracy the sonically pure characteristics of the Silver Seven Vacuum Tube Reference Amplifier.

NOTE: Please read this section thoroughly and properly make all connections BEFORE you plug in or turn on your Amplifier.

Amplifier Placement

The TFM-25/TFM-22 is convection-cooled and requires clearance for air to reach the ventilation slots on the top, bottom, and sides of the unit.

Do NOT place the amplifier on deep-pile carpeting or any similarly resilient surface that might tend to block its ventilation slots from air circulation.

The TFM-22/TFM-25 can be placed in an equipment rack which has adequate ventilation. Although Magnetic Field Power Amplifiers don't run hot, they must receive convection cooling from air moving through the unit. If your shelves do not have open backs, make sure there are vent holes in them. The situation you want to avoid is placing your power amplifier in a sealed cubbyhole such as that created by two shelves abutting a solid cabinet back panel. That creates a static air space where temperatures can rise quickly. The other components in the rack should have adequate shielding to prevent picking up hum.

Front Panel

1. POWER SWITCH. The TFM-22/TFM-25's POWER switch is located on the upper left-hand corner of the front panel.

The TFM-22/TFM-25 is designed to be connected to the convenience outlet on your preamplifier or directly to a wall outlet and controlled by the POWER switch provided on the front panel. However, the POWER switch may be left in the ON position when the power line cord is connected to a SWITCHED OUTLET rated at least 500 W, if available on the rear panel of your preamplifier.

NOTE: When the unit is first switched ON, the inputs will be muted for about four seconds to allow the amplifier to stabilize. This transient delay circuit helps prevent speaker-damaging THUMP's when powering up. But because we cannot vouch for the rest of your signal chain, it is suggested that you turn on the TFM-22/TFM-25 after your preamplifier, CD player, tuner, etc. However, make sure that a loud signal source is not playing through the preamplifier when you turn on the power amplifier.

2. POWER METERING. The TFM-25 employs ballistically-weighted analog power meters which are calibrated in Volume Unit (VU) dB, and two logging scales extending from 1 to 9, and 1 to 3. The logging scales are meant to be used as relative indications of amplifier output voltage. The primary Volume Unit scale indicates +2dB as its top value, showing 0dB to be equal to 225 watts for sine waves. Meter ballistics included a specified amount of over-shoot which is the standard of Volume Units. Therefore, on much musical material, the meter will often go past 0dB and all the way to +3dBW. At this point, the TFM-25 headroom will be exhausted. Because different musical material interacts differently with the ballistics of the meter, the best way to tell if the amplifier is overloaded is to simply listen. If you hear distortion at the same time the meter is "pegging", you have probably exhausted the TFM-25's power reserves.

The TFM-22 employs two clipping LED's, one for each channel. If one or more likely both flash, the TFM-22 has exhausted its headroom and is

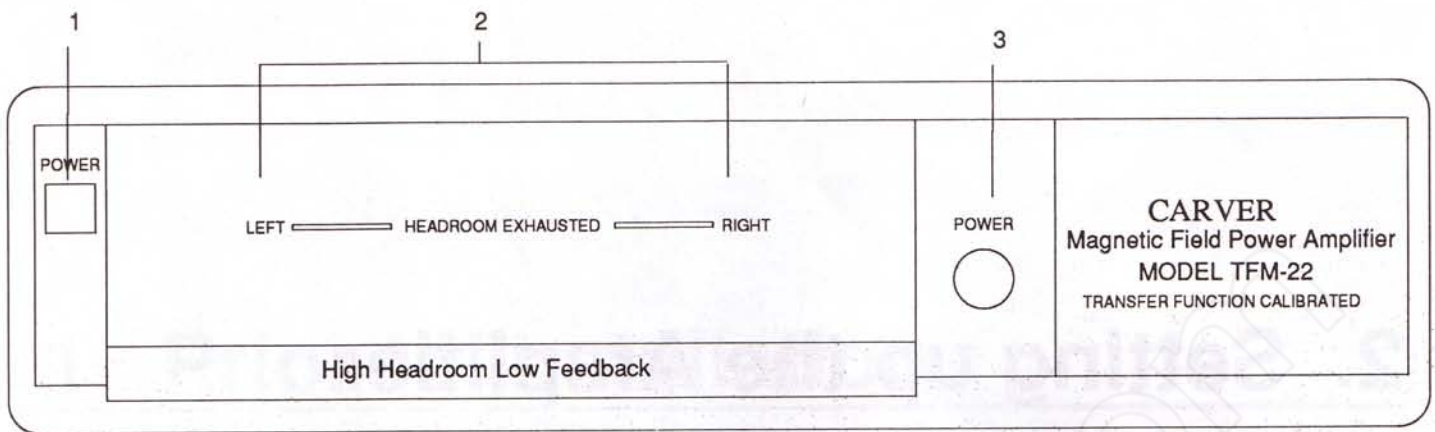

Figure 1 TFM-22 Front Panel

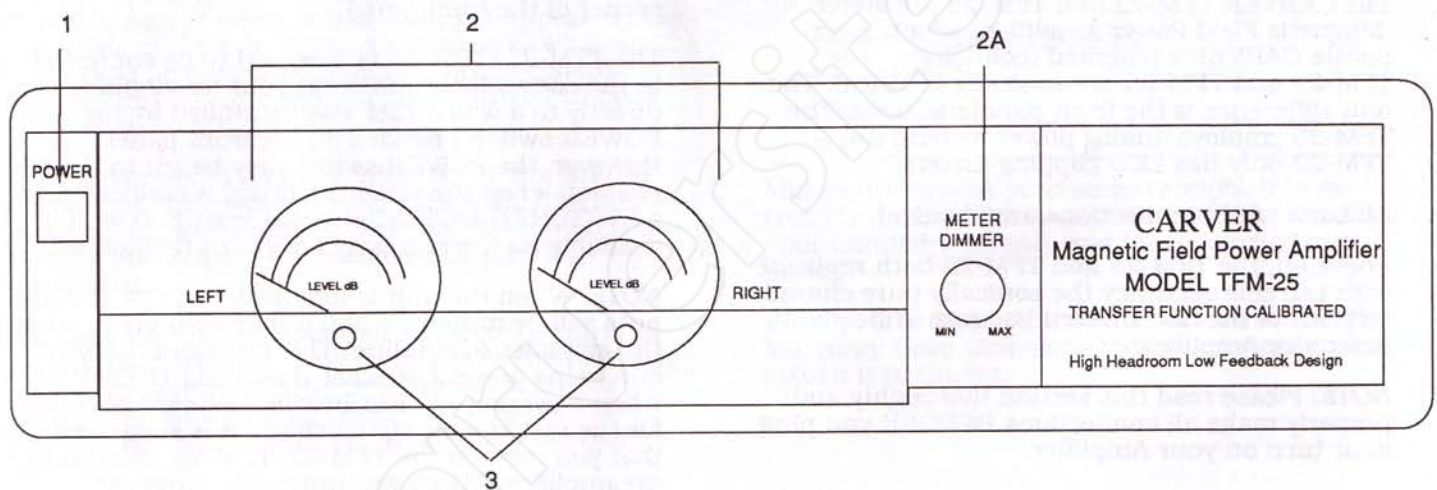

Figure 2 TFM-25 Front Panel

momentarily "clipping". Very short, intermittent lighting of the LED's is acceptable to most listeners and certainly will not over-tax the TFM-22. (It does indicate that you have reached the maximum recommended volume, however.) Constant flashing of the LED's or a condition where they stay on almost all the time indicates the amplifier is being overloaded. As with the TFM-25, different musical material interacts differently with the TFM-22's metering system. Thus the best way to tell if the amplifier is audibly clipping is to simply listen. If you hear distortion at the same time the LED's are flashing, you have probably exhausted the TFM-22's power reserves. If these LED's only light up occasionally, there will generally not be audible distortion.

2A. METER DIMMER (TFM-25 ONLY). This rotary control adjusts the brightness of the meters, depending on your taste and ambient light level in the listening room.

3. POWER Indicator(s). Light when the TFM-22/TFM-25 is on.

Rear Panel

1. STEREO/MONO SWITCH. For normal stereo operation, this switch should be left in the STEREO position. By moving it to the MONO position — and making DIFFERENT speaker connections — the TFM-22/TFM-25 can be used as a 350-watts mono power amplifier without use of any special bridging adapter. See instructions on page 10 for mono connections.

2. LINE LEVEL INPUTS. The TFM-22 and TFM-25 are designed to be compatible with virtually any quality preamplifier or CD player direct output.

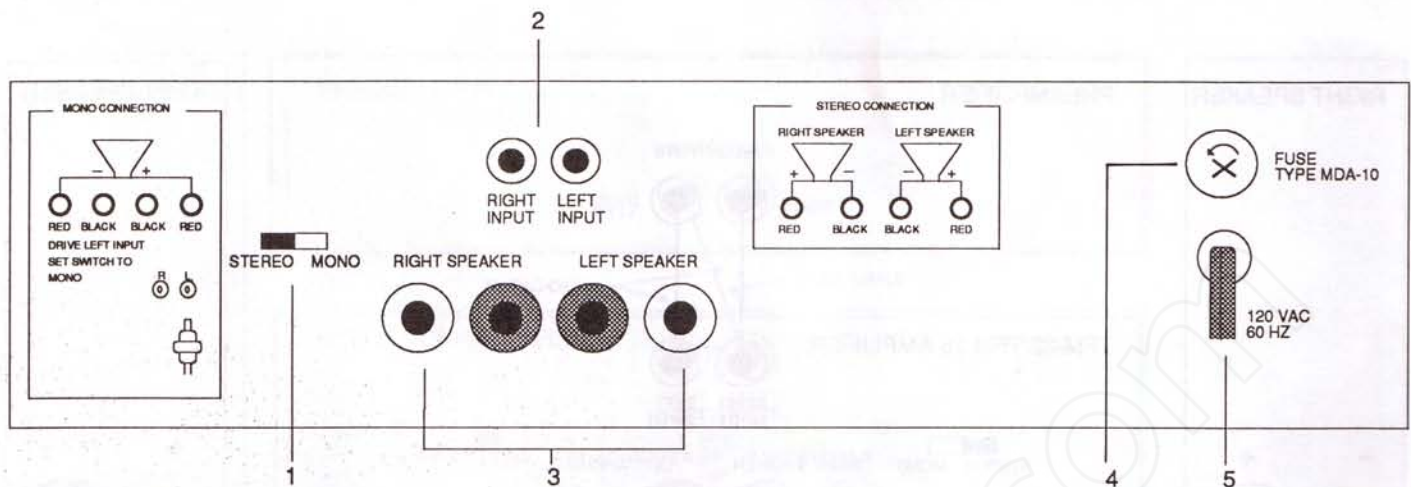

Figure 3 TFM-22/TFM-25 Rear Panel

3. SPEAKER TERMINALS. These multi-way binding posts are designed for banana plugs, spade terminals or direct wire connections. Consult your Carver Dealer for recommendations on various speaker wire termination methods. There are also many excellent brands of speaker cables available from your Dealer. Ordinary lamp cord (zip cord), available in bulk from hardware stores, is also suitable for speaker cables provided you use no thinner than #18 gauge. For runs of over 20 feet, we recommend #16 or #12 gauge. If one of these heavier wire gauges is used, make sure that it will fit inside of the plastic cap on the binding post without stray wires sticking out. Just one can cause a short circuit!

4. FUSE. The fuse value and type allows the TFM-22/TFM-25 to track the most powerful musical waveforms without compromising amplifier protection. Do NOT increase the fuse value under any circumstance. Replace with original value and type only.

5. LINE CORD. The TFM-22 and TFM-25 have a soft start power supply and may be plugged into an extension cord, splitter or properly rated preamplifier convenience outlet (1700 W). Avoid using thin, lightweight cords. Note that one line plug prong (spade) is slightly wider than the other and will only insert one way into an outlet. Make sure this polarity is maintained if an extension cord is used.

Sometimes, current pulses flowing into the power amplifier can disturb a preamplifier's low level stages and cause some hum. If this occurs, discontinue using the preamplifier convenience outlet.

Connections for Stereo Operation

1. Make sure that the power amplifier is turned off. Better yet, actually disconnect it from the wall socket momentarily.
2. Use standard audio cables to connect the RIGHT and LEFT INPUTS on the rear panel of the TFM-22/TFM-25 to the appropriate OUTPUTS of the preamplifier. Refer to your preamplifier Owner's Manual.
3. If you are using un-terminated speaker wires, prepare them by stripping 1/2" of insulation from the end of the cable. Avoid nicking or damaging the conductor.
4. Twist the strands of wire together so that all the strands will fit inside the insulating cap of the binding post.
5. Follow the diagram on the rear panel of the TFM-22 or TFM-25. Unscrew the binding post cap and insert the wires in the slots so that no bare wire will be showing when the cap is tightened.
6. Make sure that you have identified the "+" and "-" conductors on both right and left speaker wires. If you are using zip cord with a solid colored insulator, note that one half of the insulator will usually have parallel lines embossed in it. Some zip cord also has a single strand of yarn mixed in with one of the copper conductors. If the zip cord has a transparent conductor, it is common practice to use the "copper" conductor for "+" connections and the "silver" conductor for "-" connections.

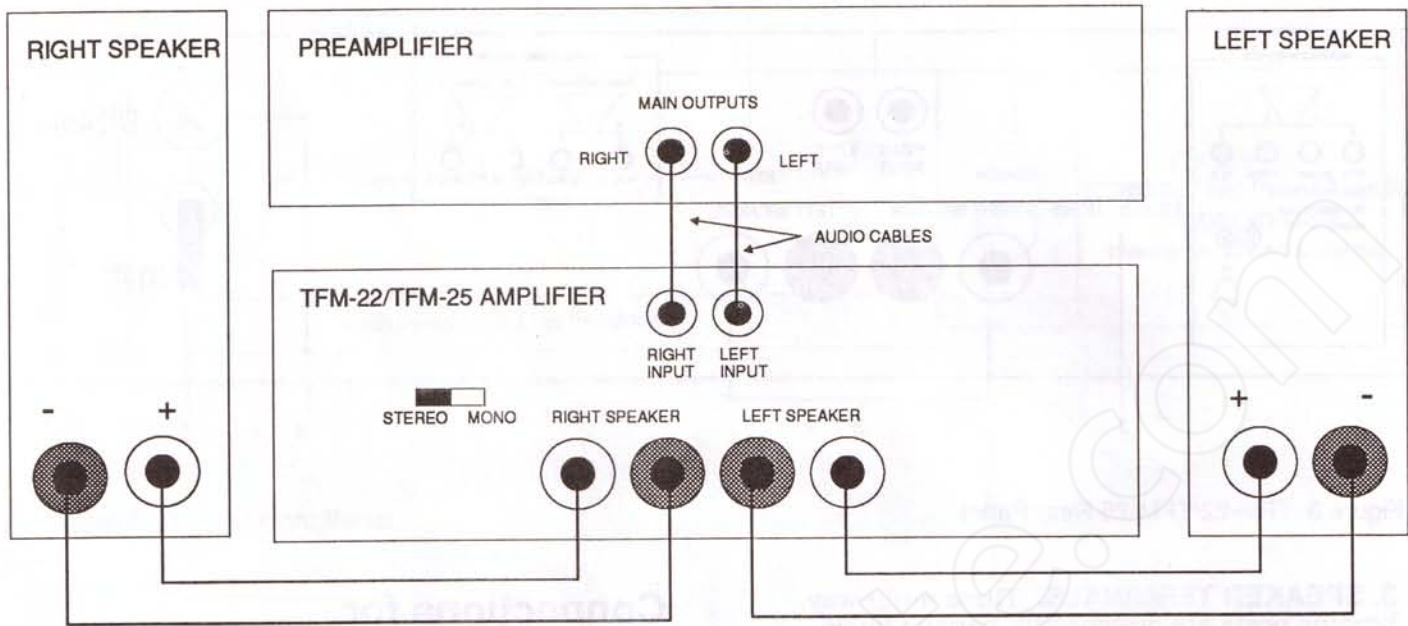

Figure 4 Connections for Stereo Operation

Whatever method you use, make sure that the same polarities are observed when you connect up the speakers. In other words, "plus hooks to plus and minus hooks to minus".

7. Tighten the power amplifier speaker terminal caps securely. Check to make sure that all strands of wire are inside the connection.
8. Loudspeakers must be connected with consistent polarity for correct phasing between them. Incorrect phasing will do no physical harm, but bass response will be diminished. This may sound redundant, but we repeat: Be sure that both speakers are connected in the same way; positive (+) speaker terminal to positive (+) amplifier terminal, and negative speaker terminal (-) to negative (-) amplifier terminal.

NOTE: The output of TFM-22/TFM-25 can develop hazardous voltages. Care should be used in connecting the speakers in order to prevent electric shock or damage to the amplifier. It is important that NO adjustment or alteration of speaker wiring is made when the unit is switched ON.

Connections for Mono Operation

When used as a mono power amplifier, only one of the TFM-22/TFM-25's inputs and just one of the four speaker terminals are used.

1. Switch the amplifier's STEREO/MONO switch to MONO.
2. Connect one input from the preamplifier to the LEFT input on the TFM-22/TFM-25. Even if it is the RIGHT channel from the preamplifier, it should be connected to the LEFT input on the TFM-22/TFM-25. At no time during mono operation should an input be connected to the amplifier's RIGHT input.
3. The speaker leads for one channel only must be connected to the TFM-22/TFM-25's RED TERMINALS only. The black terminals remain unconnected. The (+) speaker wire connects to the red RIGHT SPEAKER binding post. The (-) speaker wire connects to the red LEFT SPEAKER binding post. Use speakers of 8-ohm or higher speaker impedance in mono operation.
4. If you are using two power amplifiers, both in mono operation, to create stereo, repeat these connections for the other channel.

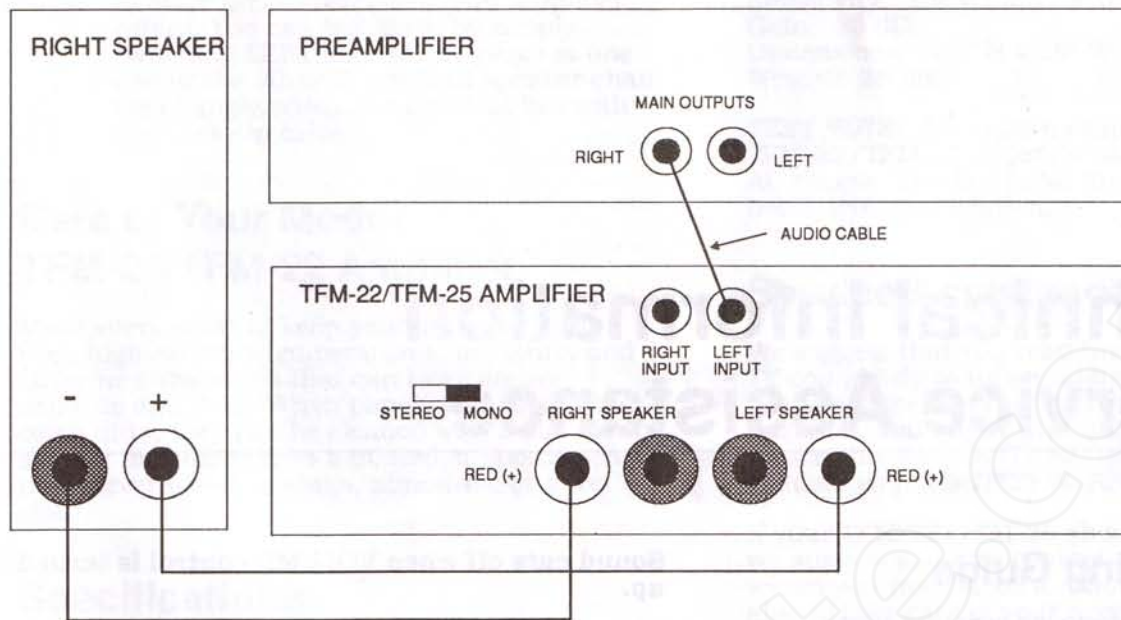

Figure 5 Connections for Mono Operation

Loudspeaker Load Impedances

The TFM-22/TFM-25 is recommended for driving loudspeaker impedances between 4 and 16 ohms. Loads in excess of 16 ohms will cause a reduction in output power. Sustained loads of much less than 4 ohms may cause premature tripping of protection circuits or cause the fuse to blow. Do NOT increase the fuse value under any circumstance. Replace with original value and type only.

Speaker Protection

NOTE: If you are using speakers that do not have a sufficient power rating and are not capable of

handling the maximum output power of the TFM-22/TFM-25, then speaker fusing is advisable. Use the fuse value recommended by the manufacturer.

Multiple Speakers

Additional pairs of loudspeakers may be connected to the amplifier in the same way as the first pair as long as the total nominal impedance is not less than 4 ohms. Switching between speakers will require an outboard speaker switching accessory.

3. Technical Information and Service Assistance

Troubleshooting Guide

Before returning you TFM-22/TFM-25 to the dealer or Service Center for repair, review the "symptoms" and "cures" in this Troubleshooting Guide. In a vast majority of situations, the problem can be traced to one of the following:

Nothing lights up on the amp when the POWER switch is turned on.

1. Line cord disconnected.
2. Poor fit between plug and wall receptacle.
3. Power off at wall receptacle (check switch with tester or lamp).
4. If amplifier is plugged into switched preamp receptacle, the preamplifier is turned off.
5. Power Amplifier fuse is blown and needs replacement with one of the same rating. **WARNING: NEVER replace or check a fuse while the unit is plugged into an AC outlet. The amplifier must be turned OFF for at least one minute before any AUDIO cables may be disconnected.**

Amplifier runs initially, then no sound.

1. Heatsink thermal switch senses high temperature. Improve top cover ventilation.
2. Transformer Thermal Switch has tripped. Allow 5-15 minutes to cool.
3. Fuse is blown. **WARNING: NEVER replace or check a fuse while the unit is plugged into an AC outlet. The amplifier must be turned OFF for at least one minute before any AUDIO cables may be disconnected.**

Sound cuts off when VOLUME control is turned up.

1. Check speaker wires for a short.
2. Check speakers for damage which may have caused an internal short.
3. Make sure that the TFM-22/TFM-25 is not driving an excessively low impedance due to more than one set of 4-ohm speakers being connected at once.

No sound from both channels.

1. Check preamplifier-to-power amplifier cables.
2. Make sure that all preamplifier controls, especially TAPE MONITORS are set correctly. (A TAPE MON button accidentally pushed in is the number one cause of unexpected silence.)
3. Make sure that the correct preamplifier input sound source has been connected.
4. Check speaker fuses.

No sound in ONE channel or ONE channel has distorted sound.

1. Check preamp BALANCE control. Turn back to center position.
2. After turning the TFM-22/TFM-25 off, check speaker wire connections by momentarily switching LEFT and RIGHT speaker cables at the amplifier's speaker output terminals. If the dead channel switches sides, it's the fault of either the speaker wire or the speaker.
3. Check speaker fuses.

4. Replace preamplifier-to-power amplifier cables. You can test them by simply switching LEFT and RIGHT plugs at one end or the other. If the dead speaker channel changes sides, the problem lies with the hook-up cable.

Care of Your Model TFM-25/TFM-22 Amplifier

Make every effort to keep your amplifier away from high external temperatures, moisture, and airborne substances that can leave greasy deposits and dust. When panels and covers become dirty, they can be cleaned with a soft cloth slightly moistened with a diluted ammonia solution. Never use detergents, abrasives, or a wet cloth.

Specifications

Power: **225 watts RMS per channel into 8 ohms both channels driven, 20-20kHz with no more than 0.5% THD.**

350 watts RMS per channel into 4 ohms both channels driven, 20-20kHz with no more than 0.5% THD.

350 watts RMS mono output into 8 ohm load.

Frequency Response: +.5dB 20-20kHz.

IM Distortion: Less than 0.5%.

Noise: 100dB A-weighted referenced to rated power.

Input Impedance: 115 K ohms.

Sensitivity: 1.5 V RMS for rated 8 ohm power.

Gain: 30 dB.

Dimensions: 4.7" H x 19" W x 14.3" D.

Weight: 26 lbs.

TEST NOTE: Accurate measurement of the TFM-22/TFM-25 depends on a sufficiently "stiff" AC supply. The 60 Hz AC line distortion must be below IHF specification.

Service Assistance

We suggest that you read the LIMITED WARRANTY completely to fully understand what your warranty/service coverage constitutes, and its duration. You **MUST** promptly complete and return the WARRANTY REGISTRATION CARD to validate your LIMITED WARRANTY.

If your TFM-22/TFM-25 should require service, we suggest you first contact the Dealer from whom you purchased it. Should the Dealer be unable to take care of your needs, you may contact CARVER Service Department by phoning (206) 775-6245, or by writing CARVER CORPORATION Service Department, P.O. Box 1237, Lynnwood, WA 98046. We will then direct you to the nearest in our national network of Authorized Warranty Service Centers, or give you detailed instructions on how to return the product to us for prompt action.

We wish you many hours of musical enjoyment. If you should have questions or comments, please write to us at the above address.

Appendix

Magnetic Field Amplifier and Transfer Function Modification

Magnetic Field Amplification

The Magnetic Field principle itself enables a power supply to process large amounts of energy, and to store energy reserves in a unique, highly efficient way. While a Magnetic Field Power Supply actually stores more joules of energy than conventional supplies, it uses six distributed capacitors instead of just two large ones. It also uses a special type of power transformer which is much more efficient and thus doesn't need to be as big or expensive as those in conventional amplifiers of the same power.

The Magnetic Field Amplifier's Power supply is governed by electronic control circuits that directly respond to the moment-to-moment power requirements of the audio sections.

The AC power control circuitry controls the amount of power the Magnetic Field coil must store and transfer. The AC power control receives its instructions from the power demand sensing circuitry which are then transferred to the primary via the optocoupler.

For low power demands, conduction begins near the minimum voltage points for the AC line signal, and is relatively brief in duration. As more drive becomes needed, conduction begins earlier and lasts longer.

The employment of High, Mid and Low DC power supplies permits biasing the output stage of the low power AMP to near class "A". Much less power is dissipated at low output levels while providing higher DC power supply voltages when higher amplification is required. Accordingly, the TFM-22/TFM-25 dissipates little of the energy it processes as heat.

The Carver TFM-22/TFM-25 Amplifier's power supply is modulated on a signal-demand basis. It uses Low, Mid and High DC power supply voltages combined with Low, Mid and High power amplification stages to increase your Amplifier's power from a 35 watt amplifier into a 400 plus watt-per-channel amplifier. The result is high efficiency, with large output capability.

The TFM/22-TFM-25 incorporates a main fuse along with specifically designed protection circuits to protect the amplifier and loudspeakers. If the unit is used in a poorly ventilated location or in a position exposed to direct sunlight and high power output, heat may not be sufficiently dissipated and the temperature may rise abnormally. In cases like this, the protection circuit will be activated if the temperature of the heat sinks rise to more than 100° C. Excessive current is limited through the amplifier's output transistors when the speaker wires at either the amplifier or speaker terminals are shorted. Excessive current is also limited into abnormal loads, for example, a damaged speaker or too many speakers wired in parallel. If such a short or an abnormal load occurs, the amplifier's inputs are muted protecting both the amplifier and

the speakers. The Magnetic Field coil is internally protected by a 150° C thermal cut-out switch. This switch protects the transformer from damage due to overheating under abnormal conditions. If one of the components inside the amplifier should malfunction and cause the amplifier to produce a significant DC voltage, the amplifier will power down to a safe output level. This circuit is activated when a DC voltage of more than + 4.5 V is detected. If excessive non-musical/high frequency signals occur, the amplifier will mute the inputs, thus protecting both the speakers and the amplifier.

Transfer Function Modification

The TFM-22 and TFM-25 Magnetic Field Power Amplifiers come closer to achieving the warmth and richness of "tube sound" than any previous Carver solid state designs. In the opinion of many serious listeners, these amplifiers deliver tight, effortless low bass and loft a wide spacious sound field of the type you'd expect from an esoteric vacuum tube audiophile design (in this case, Bob Carver's Silver Seven, which will be described in detail farther on.) We will attempt to explain why these sonic characteristics can be realistically replicated in a solid state design.

The explanation goes much farther than simply, "the TFM-22 and TFM 25 were designed to sound like tube amplifiers". It is based on *solid science*, using a two-step process:

1. **BRUTE FORCE.** We created a powerful amplifier design capable of simultaneous high current and high voltage output for the requirements of today's dynamic sources and demanding speaker loads. It takes advantage of Magnetic Field technology's ability to convert more of the incoming AC cycle into raw power and then store more joules of energy for peak music demands than conventional designs. In other words, we began with a rugged, rock-solid amp configuration.
2. **FINESSE.** Bob Carver then applied his Transfer Function Modification technique to give the TFM-22 and TFM-25 the sonic characteristics of his Silver Seven tube amplifier. By analogy, you might think of the basic TFM/Magnetic Field Amplifier design as the well-blended ingredients for a cake: flour, eggs, etc. Transfer function would then represent the flavoring — chocolate, lemon, vanilla. The essence which gives the overall creation its distinct character. Because Bob has derived a precise laboratory method for "distilling" the sonic essence of a particular amplifier design (just like a flavor can be extracted), he can apply that same essence (transfer function) to another design.

What is transfer function? Transfer function is the mathematical relationship between a power amplifier's input and output. In its most basic terms, transfer function can be thought of as amp output divided by input. Thus the "perfect" amplifier would have a transfer function of 1.

Due to the realities of electronics, a perfect transfer function is as yet unattainable. Every amplifier — be it a \$17,500 monoblock tube model, or a \$129 solid state loss-leader special — changes the input signal internally. Amplitude changes, phase shift, frequency variations over bandwidth, harmonic distortion, intermodulation distortion, clipping, ringing, slew rate differences and a hundred other complex factors assure a measurable change between amplifier input and output. Thus the transfer function of an amplifier is its unique, individual character. Its sonic signature. Its essence.

Subjectively or objectively classifying these unique "fingerprints" has kept audiophiles and engineers busy for decades. Engineers come up with new measurements, more precision in their old measurements, etc.; audiophiles coin new descriptive terms and things go round and round.

Bob Carver reasoned that both sides were right. As a highly trained and discriminating listener, he certainly accepted the vast sonic differences between amplifier designs and models and could whip up a batch of adjectives as well as the next audiophile. As a scientist, he, too, had the desire to wade in with a squad of test instruments and express the whole thing in a page of numbers and graphs.

What's the point of either exercise? Comparison. A way to express differences between designs. A way to explain why one sounds "better" than another.

The Carver Null Test, a laboratory standard. Thus Bob concluded that it would be far more useful to derive an evaluation technique that would COMPARE the sound of two different amplifiers. This test would compare Amplifier A's transfer function against Amplifier B's transfer function and express the differences between them. It would determine dissimilarities or similarities. Instead of applying numbers to individual measurements of just one amplifier, it would use those same numbers to express differences between designs.

The test configuration is remarkably simple. Two amplifiers are driven simultaneously in an externally bridged hook-up. Both receive the same input signal, which may be music, white noise, pink noise, sine waves, etc. Both are connected to carefully matched loudspeaker loads that are totally isolated from the test environment (they are used solely as loads, not as a listening source). The positive output terminals of both speakers are bridged to the outputs of a THIRD speaker.

If, at any give instant, the two amplifiers are not processing the signal in an identical manner, the positive outputs will not be at the same potential. Current will flow through the monitor speaker. What the listener will hear is the difference between the amplifiers' transfer functions. If they are close, there will be little or no sound and what there is will be musical. If the monitor speaker's output sounds distorted and unpleasant, one of the amplifiers has a non-linear transfer function. In general, the more sound from the monitor speaker, the greater the difference in transfer functions between the two amplifiers. This Null Test set-up allows two amplifiers to be compared with different speaker impedances and many different musical sources which is important if the test is to reflect the real world.

The test we've just described is not unique, secret or patented. What keeps it from being just an amusing curiosity is Bob's ability to use the Null Test results to modify transfer function. First, an amplifier with an excellent transfer function is selected as the "model" to which another amplifier is to be compared.

The Null Test Reference Standard. Currently, that reference amplifier is the Carver Silver Seven Vacuum Tube Monoblock. Destined to redefine ultra-high end values forever, the Silver Seven is truly a money-is-no-object design (\$17,500 pr.). Its sound is musical, effortless — the sound stage created is immense. Please write us for an extremely favorable review in one of the most respected high end audiophile publications which concurs.

The Silver Seven Amplifier employs classic, fully-balanced circuit topology and the finest components in existence including

A-450 Ultra-linear output transformers with oxygen-free primary leads and pure silver secondaries, Wonder Cap capacitors throughout, Van den Hul Silver interconnects, Wonder solder throughout, gold input connectors and high current gold output connectors, polished granite anti-vibration base, Simm's vibration dampers, separate power supply transformer end-bells machined from a solid block of high density aluminum.

Capable of an astonishing 390 joules energy storage, the Silver Seven delivers a conservatively rated 375 watts into 8 ohms from 20 Hz to 20 kHz with no more than 0.5% distortion. It can pump out 475 watts over a power bandwidth of 18 Hz to 40 kHz. On the 1-ohm tap, peak current is in excess of 35 amps!

The next step is to select an amplifier which will be "t-modified" to closely replicate the reference amplifiers' transfer function — in this case, the TFM-22/TFM-25 in its basic version. Note that we say "closely replicate". A 70dB null between the amplifier designs is desired. This is actually very good, considering that the average mid-fi amplifier only has about 45dB of null between the outputs of its own two channels!

The silk purse and the sow's ear. Assuming Bob can indeed replicate transfer functions, it would be easy to get the impression that just about any amplifier could be t-mod-ed into any other. This obviously isn't so. We are not suggesting — nor have we ever meant to suggest — that some ultra-cheap, badly-designed, poorly-made solid state design can be made to sound like the Silver Seven, or any other good amplifier for that matter. Transfer function replication must begin with a very robust power amplifier, one which can in many ways be as good or better than the reference design! At the very minimum, the TFM-22/TFM-25 had to equal or exceed the reference amplifier in the following parameters:

- Noise Floor
- Input/Output Impedance
- Harmonic Distortion throughout the audio band
- Voltage Output
- Current Output

Because those conditions could be met, the Transfer Function Modification process could be conducted.

The really hard part. While the actual t-modification process relies on every conceivable electronic test instrument, the key is Bob Carver's electronic engineering skills, excellent hearing and his stubborn approach to problem solving.

It entails hundred of hours of tedious cycles of meticulous and precise measurement, modification, verification, remodification, etc. repeated hundreds of times. To quote one writer, "The difficult part is not the precise definition and quantification of the difference between two amplifiers, but what to do next to cut down and finally eliminate those differences. Bob knows how to nudge a circuit a step closer to the desired measurement. It requires experience and patience."

Global and local tests. There are hundreds of possible tests which can be performed on an amplifier. Some measure a facet of overall output, others measure individual stages within the design, and still others concentrate on a single component such as a resistor or transistor. Clearly making all possible measurements would not only be unrealistically time consuming, but would lead to a huge body of data which could not be intelligently correlated.

Through years of experimentation, Bob has developed a series of inter-related tests which can lead him to specific facets of amplifier performance that affect transfer function. This system is essentially a logic tree of nested tests up to ten layers deep, all relating to the basic Null transfer function test. Global tests serve as benchmarks and pointers to still more measurements. These local tests in turn become the global test for another series of local tests. For example, a global test might be as simple as frequency response measurement. It might lead to a choice of local tests, depending on what Bob Carver is attempting to ascertain. One of those tests, for example, might be a "local" measurement of input impedance. After making that test, Bob chooses from a new series of local measurements, one of which might be on a specific inductor. That process in turn could actually lead to tests on a par-