

thecarversite.com

This manual is either an original scan from tech's who worked at Carver corp, donated by forum members, or both. These manuals are NOT intended for re-sale. If you purchased a 'Carver Manuals' disc on ebay or another auction site, and it has this material on it, you were ripped off!

Please report any resale of this material to us at thecarversite.com

thecarversite.com

OWNER'S MANUAL



TL-3300 Compact Disc Player

CARVER

Powerful · Musical · Accurate

CARVER

Powerful · Musical · Accurate

thecarversite.com



The lightning flash with arrowhead symbol, within an equilateral triangle, is intended to alert the user of the presence of uninsulated "dangerous voltage" within the product's enclosure; that may be of sufficient magnitude to constitute a risk of electric shock to persons.



The exclamation point within an equilateral triangle is intended to alert the user of the presence of important operating and maintenance (servicing) instructions in the literature accompanying the appliance.

Safety Instructions

- 1** Read Instructions - All the safety and operating instructions should be read before the component is operated.
- 2** Retain Instructions - The safety and operating instructions should be retained for future reference.
- 3** Heed Warnings - All warnings on the component and in the operating instructions should be adhered to.
- 4** Follow Instructions - All operating and other instructions should be followed.
- 5** Water and Moisture - The component should not be used near water - for example, near a bathtub, washbowl, kitchen sink, laundry tub, in a wet basement, or near a swimming pool, etc.
- 6** Ventilation - The component should be situated so that its location or position does not interfere with proper ventilation. For example, the component should not be situated on a bed, sofa, rug, or similar surface that may block the ventilation openings; or placed in a built-in installation such as a bookcase or cabinet that may impede the flow of air through the ventilation openings.
- 7** Heat - The component should be situated away from heat sources such as radiators, or other devices that produce heat.
- 8** Power Sources - The component should be connected to a power supply only of the type described in the operating instructions or as marked on the component.
- 9** Power-Cord Protection - Power-supply cords should be routed so that they are not likely to be walked on or pinched by items placed upon or against them, paying particular attention to cords at plugs, convenience receptacles, and the point where they exit from the component.
- 10** Cleaning - The component should be cleaned only as recommended in this manual.
- 11** Non-use Periods - The power cord of the component should be unplugged from the outlet when left unused for a long period of time.
- 12** Object and Liquid Entry - Care should be taken so that objects do not fall into and liquids not spilled into the inside of the component.
- 13** Damage Requiring Service - The component should be serviced by qualified service personnel when:
 - A. The power-supply cord or the plug has been damaged; or
 - B. Objects have fallen, or liquid has been spilled into the component; or
 - C. The component has been exposed to rain; or
 - D. The component does not appear to operate normally or exhibits a marked change in performance; or
 - E. The component has been dropped, or the cabinet damaged.
- 14** Servicing - The user should not attempt to service the component beyond those means described in the operating instructions. All other servicing should be referred to qualified service personnel.
- 15** Power lines - An outdoor antenna should be located away from power lines.
- 16** To prevent electric shock do not use this (polarized) plug with an extension cord, receptacle or other outlet unless the blades can be fully inserted to prevent blade exposure.

EXAMPLE OF ANTENNA GROUNDING ACCORDING TO NATIONAL ELECTRICAL CODE INSTRUCTIONS CONTAINED IN ARTICLE 810 - "RADIO AND TELEVISION EQUIPMENT"

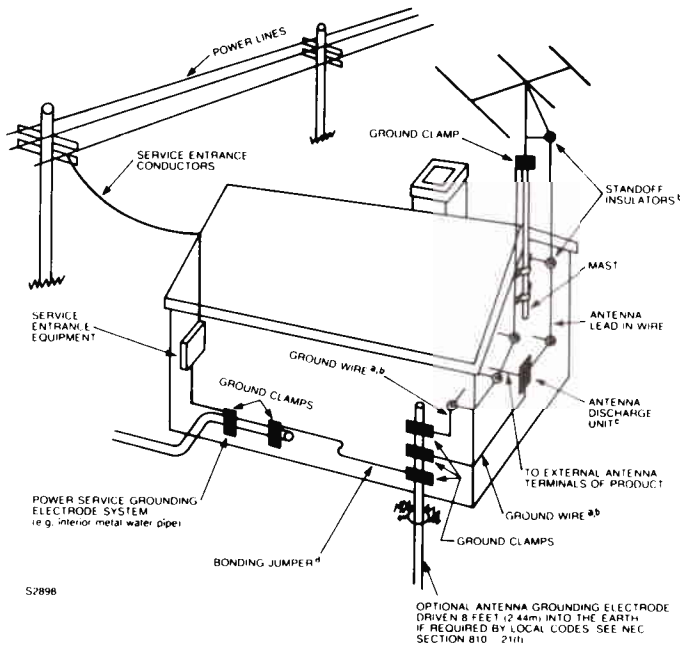

- Use No. 10 AWG (5.3 mm²) copper, No. 8 AWG (8.4 mm²) aluminum, No. 17 AWG (1.0 mm²) copper-clad steel or bronze wire, or larger, as a ground wire.
- Secure antenna lead-in and ground wires to house with stand-off insulators spaced from 4-6 feet (1.22-1.83 m) apart.
- Mount antenna discharge unit as close as possible to where lead-in enters house.
- Use jumper wire not smaller than No. 6 AWG (13.3 mm²) copper, or the equivalent, when a separate antenna-grounding electrode is used. See NEC Section 810-21 (j).

Pour prévenir les chocs électriques ne pas utiliser cette fiche polarisée avec un prolongateur, une prise de courant ou une autre sortie de courant, sauf si les lames peuvent être insérées à fond sans en laisser aucune partie à découvert.

17 Grounding or Polarization - Precautions should be taken so the grounding or polarization means of the component are not defeated. Section 810 of the National Electrical Code, ANSI/NFPA No. 70-1984, provides information with respect to proper grounding of the mast and supporting structure, grounding of the lead-in wire to an antenna discharge unit, size of grounding conductors, location of antenna-discharge unit, connection to grounding

Carts and Stands - The appliance should be used only with a cart or stand that is recommended by the manufacturer.

An appliance and cart combination should be moved with care. Quick stops, excessive force, and uneven surfaces may cause the appliance and cart combination to overturn.

PORTABLE CART WARNING



electrodes, and requirements for the grounding electrode.

* External line voltage selector switches should only be reset by qualified service technicians for proper attachment plug for alternate voltage. See an authorized dealer for more information.

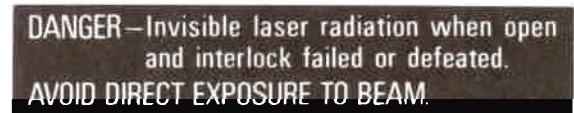

THIS DIGITAL APPARATUS DOES NOT EXCEED THE CLASS A/CLASS B (whichever is applicable) LIMITS FOR RADIO NOISE EMISSIONS FROM DIGITAL APPARATUS AS SET OUT IN THE RADIO INTERFERENCE REGULATIONS OF THE CANADIAN DEPARTMENT OF COMMUNICATIONS.

LE PRÉSENT APPAREIL NUMÉRIQUE N'ÉMET PAS DE BRUITS RADIOÉLECTRIQUES DÉPASSANT LES LIMITES APPLICABLES AUX APPAREILS NUMÉRIQUES DE CLASSE A/DE CLASSE B (selon le cas) PRESCRITES DANS LE RÈGLEMENT SUR LE BROUILLAGE RADIOÉLECTRIQUE ÉDICTÉ PAR LE MINISTÈRE DES COMMUNICATIONS DU CANADA.

Introduction

A Message From Bob Carver

Dear CARVER Customer,

Thank you for choosing CARVER electronics. We at CARVER CORPORATION realize that there is an abundance of home electronics from which to choose, and the differences between the various models are not always apparent at first glance. CARVER CORPORATION strives to produce for you the finest in audio reproduction equipment which integrates the latest and best technology with the most competitive price possible.

Each piece of our electronics is feature-packed with advances that are unrivaled. When you purchase our products you are receiving electronics that will provide you with years of enjoyment.

You are about to enter the remarkable world of digital audio with its increased dynamics, frequency response, and hiss-free performance. You have chosen a first-quality Compact Disc Player with triple-beam laser scanning, 8 times over sampling, and dual 18-bit digital/analog converters.

In addition, the Digital Time Lens (DTL) sets the TL-3300 apart from all other Compact Disc Players. The DTL is an extremely sophisticated circuit which prevents the loss of sonic front-to-back depth imaging, as well as the excessive



brightness sometimes associated with compact disc recordings.

How and when you use the DTL depends on your choice of discs, your type of speakers, and your own musical taste. We have included an explanation of why the Digital Time Lens was invented and what it can do for you in Chapter 6.

I am proud to present to you the best in craftsmanship and design found in CARVER electronics.

Robert W. Carver, President
CARVER CORPORATION

Table of Contents

Safety Instructions	4
Introduction	6
1	
Prior to Installation	9
<i>A Definition of the TL-3300 Compact Disc Player</i>	
<i>Unpacking Your Compact Disc Player</i>	
<i>Removing the Transport Screws</i>	
<i>Placement of the TL-3300</i>	
2	
Front Panel and Controls	11
<i>Front Panel</i>	
<i>Remote Control</i>	
3	
Rear Panel and Connections	14
<i>Rear Panel</i>	
<i>Connections</i>	
4	
Operating Your Compact Disc Player	16
<i>Playing a Compact Disc</i>	
<i>Pausing Playback</i>	
<i>Stopping Playback</i>	
<i>Moving to Another Selection</i>	
<i>Programmed Playback</i>	
<i>Index Search</i>	
<i>Repeat Playback</i>	
<i>Specific Phrase Repeat</i>	
5	
About Compact Discs	20
<i>The Problem</i>	
<i>The Compact Disc Solution</i>	

6
Digital Time Lens 22
Introduction
The Digital Time Lens

7
Technical Information and Service Assistance 24
Troubleshooting Guide
Radio and TV Interference
Handling Compact Discs
Specifications
Service Assistance

thecarversite.com

Prior to Installation

NOTE: Do not connect the TL-3300 to AC power until all signal connections have been made and the installation is complete.

A Definition of the TL-3300 Compact Disc Player

The CARVER TL-3300 Compact Disc Player brings you the outstanding performance of digital audio recording: increased dynamics, uniform frequency response, and hiss-free performance.

The TL-3300's performance is further enhanced by the proprietary Digital Time Lens which restores the ambiance and spatial detail sometimes missing from digital audio recordings.

Unpacking Your Compact Disc Player

Make a note of the serial number which is located on the back of the player. Record it in the space provided for convenient reference! You will need to refer to this number if you require service or if the Compact Disc Player is stolen.

Model TL-3300 _____

Serial Number 9037570253

Purchased at _____

Date _____

Please save the box, as well as all of the internal packing materials!

This container is the best way to store and move your new Compact Disc Player. If the player should need repair, the original container is ideal for shipping to a CARVER Service Center.

Upon opening the box, please check for any visible sign of damage that does not appear on the outside of the box. If you do encounter what appears to be concealed damage, please consult your Dealer before proceeding to further unpack the unit.

If no damage is found, gently lift out the unit by grasping the handles. After lifting the Compact Disc Player out of the box, gently lift first one side, then the other and remove the molded side packing material. Inside the box you will also find the remote control and batteries.

Figure 1 Transport Screws

Note:

Before using, the three red colored screws must be removed.

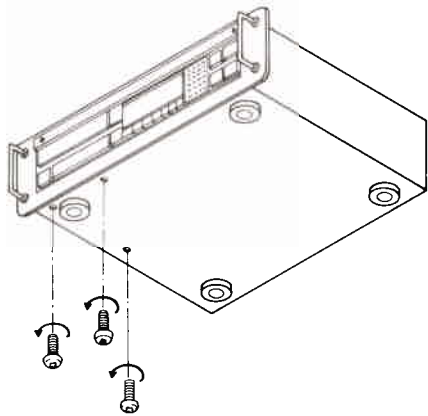

Removing the Transport Screws

To protect the Compact Disc Player during transport, three red transport screws were used to secure the delicate laser assembly. These screws are attached to the **BOTTOM** of the TL-3300.

CAUTION: These screws must be removed before any attempt is made to operate the Compact Disc Player!

To remove the transport screws:

- 1 Gently turn the Compact Disc Player upside down and rest it on a soft non-abrasive surface.
- 2 Locate the red transport screws near the front and left side of the unit.
- 3 Remove the screws using a Phillips screwdriver.

- 4 Keep the red transport screws in a safe place so that they may be replaced before moving the unit.
- 5 Should you move, or need to ship the Compact Disc Player for service, replace the red transport screws using the same procedure. Make sure that there is no disc in the player before putting the screws back.

Placement of the TL-3300

Consider the following guidelines in placing your Compact Disc Player with your other stereo components:

- 1 The TL-3300 Compact Disc Player should not be placed directly next to, or on top of your receiver or tuner.

To avoid possible interference, we suggest that the TL-3300 be positioned at least one component away when stacking or placing your equipment in a row on a shelf. Also, avoid placing the TL-3300 next to or on top of a television set, cable converter box, or video cassette recorder.

- 2 Make sure that no other components are placed on top of the TL-3300. Also, avoid placing stacks of heavy records or a speaker on top of the unit.
- 3 As with all high-quality components, avoid placing the TL-3300 in direct sunlight or where it will receive unnecessary hot air currents from an amplifier or heat outlet.

2

Front Panel and Controls

Front Panel

1 POWER (AC Power Switch)

This is a push on/push off switch that applies or removes power to the unit. Push once to turn the TL-3300 on; push again to turn the TL-3300 off.

2 DISC TRAY

This is the opening where you put the compact discs. The tray works like a drawer, moving in and out as you activate the OPEN/CLOSE button. The tray closes by itself if you push it in lightly. Keep it closed when you're not using the unit to keep the laser pickup clean and protected.

3 OPEN/CLOSE

Press this button once to slide the disc tray out, then press it again to retract it.

4 DTL (Digital Time Lens)

Press this button once to turn the Digital Time Lens on; press again to turn the DTL off. When DTL is on, the word "DTL" is illuminated in the display.

5 REPEAT

Press once to activate a repeat playback cycle for the entire disc or programmed disc selections. Press it again to cancel the repeat playback function.

6 A-B

Use this button to set starting and ending points for repeat playback. You can choose points anywhere on the disc, then repeat playback indefinitely.

7 TIME REMAINING

Press this button to display the remaining playing time on the entire disc in minutes and seconds (min:sec). Press TIME REMAINING again to display the time remaining on the current selection. Press again to display the elapsed time. By pressing this button repeatedly, you can display all three time measurements.

8 MULTIFUNCTION DISPLAY

This fluorescent display panel helps you keep track of the TL-3300's various functions:

- "TRACK" displays the current track number

Figure 2 Front Panel

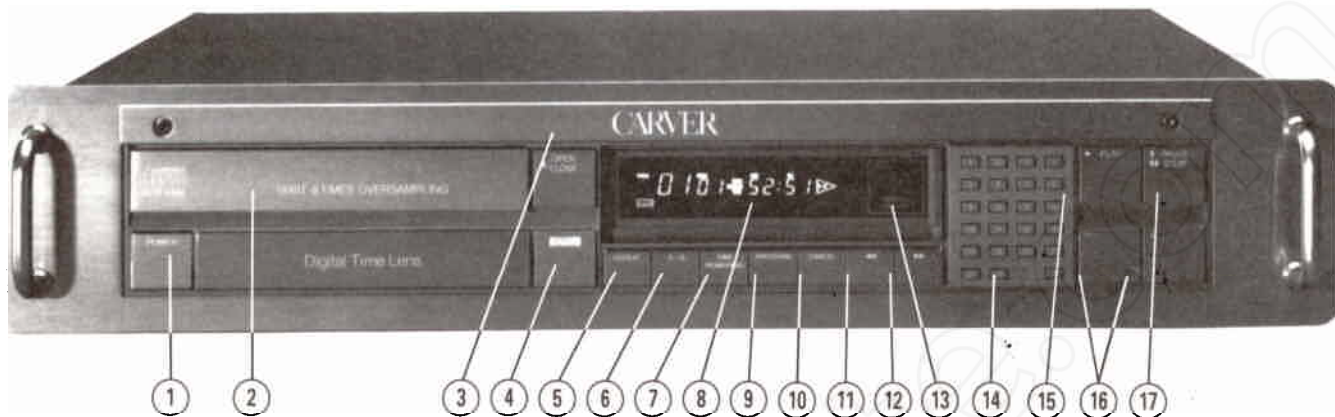

- "TIME," "TOTAL REMAIN TIME," or "REMAIN TIME" displays either the current elapsed time, the total remaining playing time on the disc, or the time remaining on the current selection. You can toggle the display by repeatedly pressing the TIME REMAINING button on the front panel or the remote control unit.
- "PROGRAM" appears when the program feature has been selected. The current program number is displayed to the right of the word "PROGRAM."
- "REPEAT" signals that this feature is in operation.
- "A-B" flashes as the beginning and ending points are being selected, then remains lit as long as this feature is in operation.
- "PLAY" is lit as long as the TL-3300 is in play mode, but flashes when the PAUSE/STOP button is pressed once.
- "DTL" lights when the Digital Time Lens is on.

9 PROGRAM

This button is part of the TL-3300 Compact Disc Player's sophisticated programming playback system and is used when setting the selection order.

10 CANCEL

Press PROGRAM then CANCEL to cancel the current program.

11 << (REVERSE)

This button corresponds to the reverse button on a tape deck and moves the laser pickup back through the music.

12 >> (FORWARD)

This button corresponds to the forward button on a tape deck and moves the laser pickup forward through the music.

13 REMOTE SENSOR

This sensor receives signals from the remote control unit. The remote control can be used up to 15 feet from your Compact Disc Player and must be aimed in the player's direction.

The track number is always displayed. The additional displays described above appear as features are turned on and off.

14 TRACK SELECTION BUTTONS (0-22)

These buttons allow you to access or program a specific selection on the disc. For example, in play mode, pressing "9" immediately plays the ninth selection on the disc. Similarly, press "2" then "4" to play the twenty-fourth selection.

15 PLAY

Press this button to begin play.

16 SKIP (+) AND (-)

Digital disc technology allows you to move forward or backward on the disc. Press Minus (-) once to move back to the start of the current track. Press (-) twice to move back to the start of the previous selection.

Press Plus (+) repeatedly to move forward through the tracks or selections. Both buttons can be used in conjunction with PLAY and PAUSE as described in Chapter 4.

17 PAUSE/STOP

This is a dual-purpose button. Press the button once to temporarily interrupt play. The pickup does not move to another selection. Push PLAY to resume operation.

Press PAUSE/STOP twice to move the pickup back to the beginning of the first selection on the disc. This is analogous to using the "reject" lever on many turntables to return the tonearm to the beginning of a record. The TL-3300 is still turned on and is considered to be in playback standby mode. Press the POWER button to turn the unit completely off or press PLAY to begin play.

Remote Control

All of the TL-3300 features, except POWER ON/OFF and DOOR OPEN, are available from the Remote Control Unit:

- 4 DTL
- 5 REPEAT
- 6 A-B
- 7 TIME REMAINING
- 9 PROGRAM
- 10 CANCEL
- 11 << (REVERSE)
- 12 >> (FORWARD)
- 14 TRACK SELECTION (0-22)
- 15 PLAY
- 16 SKIP (+, -)
- 17 PAUSE/STOP

Figure 3 Remote Control

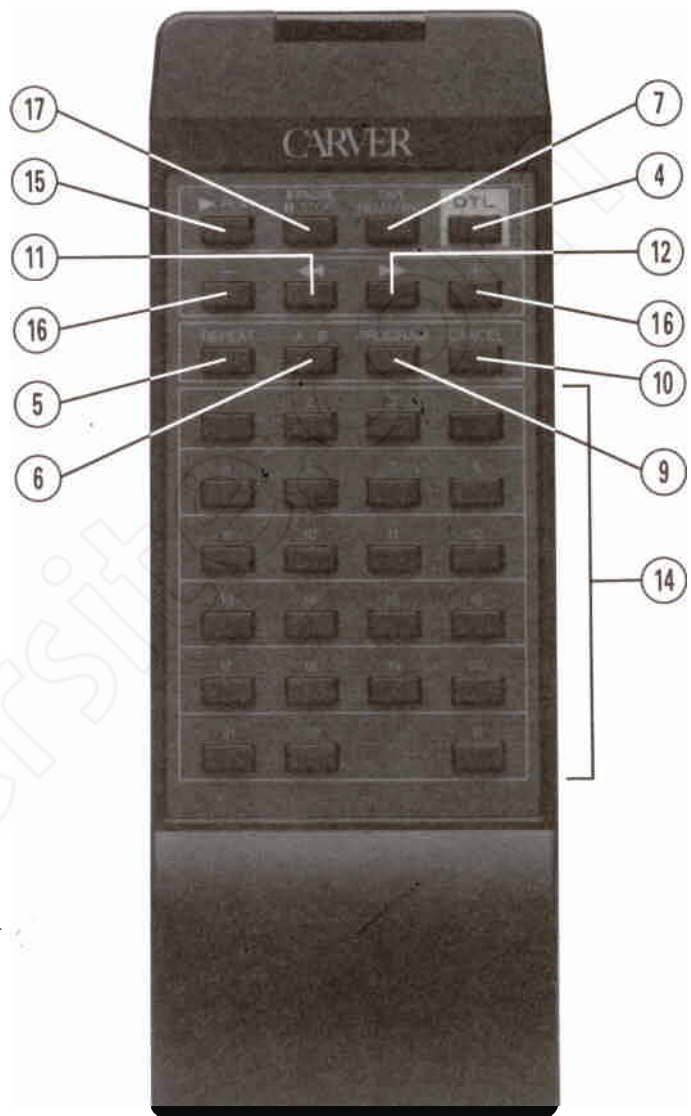

All of these features are described at the beginning of this chapter under the heading *Front Panel*. For additional information, read the operating instructions in Chapter 4.

To use the Remote Control, simply aim the unit at the Compact Disc Player from no more than 15 feet away. The word "Remote" will momentarily flash on the Remote Sensor.

Two AA batteries are needed to operate your Remote Control unit. Insert the batteries supplied into the unit by sliding the back panel open. Match the positive (+) and negative (-) polarities as indicated inside the battery compartment.

3

Rear Panel and Connections

Rear Panel

1 LINE OUT

Two jacks, labeled "LINE OUT L" and "LINE OUT R," are located at the left corner of the rear panel when the TL-3300 is viewed from the back. Using these jacks, connect the TL-3300 to your preamplifier, receiver, or preamp/tuner.

2 AC

The AC power plug is available for connecting the TL-3300 directly into a wall plug or into your preamplifier's convenience power outlet. The TL-3300 is rated at 11 watts which is well within the limits of most preamplifiers, including those made by Carver Corporation. Consult your owner's manual if you are in doubt.

Connections

Follow these steps to connect your Compact Disc Player to the rest of your system.

- 1 Make sure that the TL-3300, as well as the rest of your stereo system, is turned off or disconnected.

Figure 4 External Connections

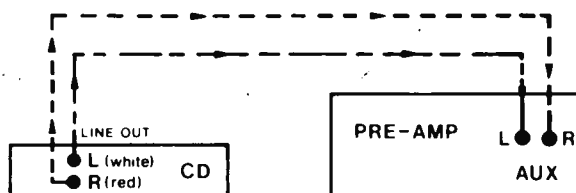

- 2 Locate the LINE OUT jacks on the Compact Disc Player's rear panel.
- 3 Connect one end of a white patch cord plug to the top (L) jack on the TL-3300.
- 4 Connect the corresponding red patch cord plug to the lower (R) jack.
- 5 Check the back of your preamplifier (or receiver, or preamp/tuner) or consult the owner's manual that came with the unit. There are several possible ways to connect the TL-3300 to your preamplifier:
 - A Use the CD inputs that are available on most newer units and are intended specifically for Compact Disc Players.

Figure 5 Rear Panel



- B Use the AUX inputs.
- C If options A or B are unavailable, use the TAPE PLAY or TAPE IN inputs. If you already have a cassette deck, use the second set of inputs which are included on most receivers and preamplifiers. NOTE: With this configuration, you may not be able to record from the Compact Disc Player.

WARNING: Never plug the TL-3300 into Phono inputs, either moving coil or moving magnetic.

- 6 When you have made your choice, plug the free end of the white patch cord into the LEFT jack and plug the free end of the red patch cord into the RIGHT jack.
- 7 Use the AC power cord to connect the TL-3300 to an AC outlet.

4

Operating Your Compact Disc Player

Playing a Compact Disc

Now you are ready to enjoy the amazing sonic clarity of compact discs.

- 1** Press the POWER button on the Remote Control or on the TL-3300's front panel. After a few seconds, you'll see the word "DISC" on the fluorescent display panel.
- 2** Press the OPEN/CLOSE button to slide the disc tray out.
- 3** Remove a compact disc from its case and place it in the drawer label side up. While compact discs are much less prone to wear and tear than records, you should still be careful with your compact discs. Gently grasp the disc on the edges only. (See *Handling Discs* in Chapter 7.)

Be careful to center the smaller, 3-inch discs in the smaller cutout area in the loading tray. These discs may be played without an adapter ring.

- 4** Press the OPEN/CLOSE button again to retract the tray. After about three seconds, the multifunction display shows the number of

tracks and the total playing time on the disc, then switches to "TRACK 00."

If the multifunction display continues to flash "DISC" after the disc tray has been retracted, see the *Troubleshooting Guide* in Chapter 7.

- 5** The TL-3300 is now ready to play according to your instructions.
- 6** If you press the TIME REMAINING button, the REMAINING TIME indicator lights and the read out shows the total playing time and the number of tracks on the disc. This information is especially helpful when you are getting ready to make tape recordings.
- 7** To begin playing the disc, simply press PLAY. If nothing happens, or the music does not sound proper, consult the *Troubleshooting Guide* in Chapter 7.

Shortcut:

Press the PLAY button immediately after placing the disc in the disc tray. The TL-3300 automatically retracts the disc tray and begins playing.

Or, press the track selector button for the track you want to play. The tray retracts and the desired track begins playing.

Pausing Playback

- 1 Press the PAUSE/STOP button once to interrupt playback. The PLAY indicator will flash.
- 2 Press PLAY to resume playback exactly where you left off.

Stopping Playback

- 1 Press PAUSE/STOP twice to stop playback at any time.

Shutting the Player Off

- 1 Press OPEN/CLOSE to slide out the disc tray and remove the disc. Push OPEN/CLOSE again to close the tray.
- 2 Press POWER to turn the unit off.

NOTE: Do not close the tray by hand when the power is off. Always use the OPEN/CLOSE button.

Moving to Another Selection

You can move from one place on the disc to another using the FORWARD and REVERSE buttons, the SKIP buttons, or the SELECTION buttons.

- 1 Use the FORWARD (>>) and REVERSE (<<) buttons just the way you would with a cassette deck. For the first three seconds, these operations are carried out at low speed, allowing you to back up or advance slightly. After three seconds, the operations switch to high-speed mode so that you can move quickly through the disc. You will hear the speeded up music at 1/4 the normal volume.
- 2 Use the SKIP (+) and (-) buttons to move forward or backward to the exact beginning of a selection, or to move quickly through the selections without listening to the intervening music.

In playback mode:

Press (+) once to move ahead one selection and immediately begin playing it. The fluorescent display now presents the track number of the next song.

Hold down the (+) button to move ahead more than one selection. The selection numbers on

the display will advance. Release the (+) button when the desired selection is reached. Play begins immediately.

The (-) button works in a similar manner to move back through one or more selections.

In pause mode:

The operation of the (+) and (-) buttons is the same, but playback does not begin until the PLAY button is pressed.

In either mode, if the (+) button is held down long enough, the TL-3300 returns to the first selection.

- 3 Use a Track Selection button to choose a specific track. In playback mode, the laser pickup moves to the selection, then begins playing immediately. In pause mode, the laser pickup moves to the selection, but play does not begin until the PLAY button is pressed.

In stop mode:

The selection button moves the pickup to the selected track and begins playing.

Programmed Playback

The Carver Compact Disc Player allows you great versatility in the order in which you listen to selections on a compact disc. You can skip selections you don't wish to hear, make up a new order, or repeat a favorite selection more than once.

This feature allows you to hear selections in any order desired with up to 24 different songs programmed at one time. Between each programmed selection, the TL-3300 inserts a three-second pause.

To program selections:

- 1 If the unit is in play mode, press PAUSE/STOP twice to place it in playback standby mode.
- 2 Press the PROGRAM button and wait at least 3 seconds. The display reads "P-01 Prog." Now you are ready to program your first selection.
- 3 Use the SKIP (+ or -) or TRACK SELECTION buttons to move to the desired selection. (NOTE: You cannot use the FORWARD, REVERSE, or A-B buttons in program mode.) You will see the track number of the selection to the left of the "P-01" on the display.

- 4 When you have reached your first selection, press the PROGRAM button again. You will see the display change to "P-02".
- 5 Pick a second selection by repeating steps 3 and 4. Program up to 24 selections in any order. You may repeat a selection more than once.
- 6 When you have finished programming the selection order, press PROGRAM, then press PAUSE/STOP. The TRACK indicator displays "P-01" for a few seconds, then cues up to the first program selection.

To review the program or make corrections:

- 1 Press PAUSE/STOP. The display changes to "TRACK 00."
- 2 Press PROGRAM to step through the programmed selections by repeatedly pressing the PROGRAM button. Any entry may be changed using the Skip or Track Selection buttons.
- 3 Continue to press PROGRAM to step through to the end of the program, as indicated by "TRACK 00" on the display.
- 4 Press PAUSE/STOP when your program is complete.

To playback the programmed selections:

- 1 Press PLAY.
- 2 If you want to advance or back up to another selection, use the SKIP buttons. But, remember, the SKIP buttons move in accordance with the programmed order. For example, if you programmed a disc to play selections 3, 5, 6, 7 and 8, the (-) button would not take you any closer to the beginning of the disc than selection 3. Similarly, the (+) button would stop at the beginning of selection 8.
- 3 Use FORWARD and REVERSE to move within the current selection. You cannot move outside of the programmed order. As in the previous example, if you held down the FORWARD button, the TL-3300 would move quickly through selections 3, 5, 6, 7, and 8.

At the end of the program, the TL-3300 automatically enters playback standby mode. Press PLAY to begin playing the disc at track number 1 or press PROGRAM, then PLAY, to repeat the programmed order.

Shortcut:

Instead of pressing PAUSE/STOP after programming your selections, press PLAY. The TL-3300 stores the programmed selections, then begins playing.

To cancel a program:

Since you won't want the same order on the next disc you play, the programmed order is cancelled automatically when you press the OPEN/CLOSE button.

You can also cancel a program by pressing PROGRAM, then CANCEL. All current program selections are erased, and the TL-3300 waits for you to enter the first program selection.

Index Search

A compact disc can hold an impressive amount of music. While this makes it an excellent medium for classical music, it also makes the Skip feature less useful in some cases.

For example, a three-movement symphony would only display three selections, or just one if the movements blend into each other without a pause. The developers of the compact disc took this into account and devised a way to further subdivide selections into indexes.

If a compact disc has been indexed it will be noted in the program booklet which came with the disc. Consult the index listing to determine the significance and placement of each index segment.

To search through a selection's indexes:

- 1 Press STOP to place the TL-3300 in playback standby mode.
- 2 Select a track number using the SKIP buttons.
- 3 Search for the index mark using the FORWARD and REVERSE buttons. The INDEX indicator lights, indicating the presence of each successive index. The fluorescent read-out displays the track first, then the index number. For example, index three on track two would be displayed as "02 03".
- 4 When you reach the index mark you are seeking, press PLAY. Playback begins from the point where the index was programmed onto the disc by its manufacturers.

- 5 To stop playback, press PAUSE/STOP; otherwise playback continues past the index mark to the end of the disc.
- 6 Index selection numbers are displayed even if the Index Search function is used with discs that do not have index markers. When play is initiated, however, it starts from the beginning of the track already selected.
- 7 If an index number is selected that is greater than the number of actual index markers on the disc, play begins from the final index marker on the disc.
- 8 In some cases, playback may begin slightly before the index mark.

NOTE: Indexing cannot be used with programmed playback.

Repeat Playback

This feature lets you repeat a whole compact disc, a complete program, or just certain selections using the programming feature.

To repeat a disc from beginning to end:

- 1 Press the REPEAT button. The corresponding fluorescent display lights in the multifunction panel. As long as this light is on, the disc will play again and again.
- 2 To cancel the repeat function at any time, press REPEAT again. The REPEAT indicator will go out indicating that repeat playback has been cancelled.

To repeat a program:

- 1 Press PROGRAM, then PLAY, then REPEAT. The TL-3300 will continue to play the programmed selections until the repeat feature is turned off.

To repeat one or more selections:

Use the program feature to program playback of one or more selections. You can program a single selection to repeat up to 24 times.

Specific Phrase Repeat

The A-B button is used to repeat a passage on a compact disc that does not start at the beginning of a selection or on an index mark.

- 1 Press PLAY to start the playback of either the disc or a specific track.
- 2 When the disc reaches the beginning of the passage you wish to repeat, press the A-B button once. The A-B indicator on the multifunction display starts flashing and the disc continues playing. This point on the disc is now set as the beginning of the repeat passage.
- 3 When the disc reaches the end of the passage you wish to repeat, press the A-B button again. The A-B indicator stops flashing, but remains lit. This point on the disc is now set as the end of the repeat passage.
- 4 The set passage continues to repeat until you press the A-B button again. The A-B indicator goes out and the disc continues to play.

5

About CDs

The Problem

Analog recording converts sound impulses into varying amounts of electrical energy, which is then used to magnetize a tape to varying degrees. The more musical impulses in a given passage of music, the more magnetism is imparted to that part of a tape as it goes past the recording head.

The trouble has always been the physical limitations of tape. It simply has a finite limit to how much energy it can record. That limit may very well be under the maximum dynamics of a bass drum, a rock band, or a symphony in the throes of a Wagner overture.

Thus, recording engineers have had to reduce the overall signal strength to allow "headroom" for unexpected loud passages. This would be fine if tape were completely silent. But there is residual energy even in unrecorded tape which is heard during playback as tape hiss. If a signal is recorded too softly, this hiss becomes apparent. In practice the signal-to-noise ratio is always less than optimal since it has been lowered to allow for loud parts.

Tape is also limited in the frequency range which it can reproduce without distortion.

Corresponding problems occur when the master tape is made into a vinyl recording. It is exceedingly difficult to cut record grooves which exactly mirror even the dynamic range and frequency response of the tape recording, much less the original performance. Add additional hiss caused by the surface of the vinyl and the compromises made during production to squeeze more time out of a record and the results are often a far cry from the live performance.

To the credit of the recording industry, there are many excellent analog discs, some of which are equal to or, according to critics, better than many compact discs. They are examples of painstaking skill in every step of the process — and are often much more expensive than compact discs.

The Compact Disc Solution

Digital recording is a relatively new method of storing sound impulses and didn't become a commercial reality until the late 1970s. It is based on computer technology rather than electronics and magnetism as is the older analog method of recording. Digital recording converts sound into pure information, strings of ones and zeros which can be recorded perfectly without concern over the limitations of magnetic tape.

A good analogy is a conveyer belt filled with an endless line of fruit baskets, representing magnetic tapes' recording ability. Conventional analog recording fills each basket with "fruit." A small amount for a quiet passage; heaping full for a loud sound. But what often happens is that there is more "fruit" than the basket can hold and the baskets cannot be made bigger. You can move them past faster so each one holds less, but still, a loud bass drum boom or a massive synthesizer note can exceed the capacity.

Digital recording is like an inspector who counts the fruit that would go into each basket. He writes down a description on a piece of paper and drops it in each basket. Nothing more. Just a precise description. With this approach, it doesn't matter how much "fruit" (or music) needs to go in a basket. The inspector (or analog-to-digital converter) can accurately write down that bass drum crash as "4.7 tons of apples" and the description still fits in the basket. He can also write down the *exact* color, size, and shape of the fruit, corresponding to digital's ability to record wide frequency response and finer detail.

Our "endless conveyer belt of written descriptions" is now transferred to a compact disc which is imprinted with microscopic pits, representing the individual data bits exactly as recorded.

The Carver Compact Disc Player TL-3300 uses a solid state semiconductor diode laser to illuminate the track of pits on the disc surface. The laser is reflected into a photo-diode which translates the on-and-off light impulses into an electronic signal.

Then special circuitry translates the digital bits back into analog electrical impulses for your amplifier.

The sound you hear has greater dynamic range, wider frequency response, and no tape hiss. And, within reasonable limits, the compact discs are impervious to scratches, dust, dirt, warping and fingerprints.

For a more detailed description of digital technology, we recommend the many excellent articles in recent stereo magazines, as well as specialized publications devoted specifically to digital audio recording.

6

Digital Time Lens

Introduction

Many professional musicians, audiophiles and audio journalists have praised the quietness, dynamic range and superb frequency response of digital discs — and then expressed a lingering disappointment over how actual commercial examples sounded. The complaint boils down to a lack of ambiance and spatial detail, along with an overly bright, hot-sounding midrange.

When Bob Carver obtained his first compact disc player, he too noticed subtle differences in many compact discs. The three-dimensional perspective which his analog system provided in lush abundance sometimes evaporated into a flat brittle wasteland.

He then purchased no less than 23 compact discs and their analog counterparts and set about quantifying the differences. True, the compact discs had better dynamic range and richer, tighter bass...but testing uncovered two inherent, measurable flaws:

- The overall frequency balance shifts slightly, with the compact disc putting out more energy above 400 Hz.

- The amount of left-minus-right channel information differs by about 1.25 dB.

The left-minus-right (L-R) component of stereo carries the three-dimensional part of sound field information. Even 1.25 dB less produced a noticeable reduction in imaging, spatial positioning and other psychoacoustic factors that put the realism into music.

The Digital Time Lens

Bob Carver's Digital Time Lens (DTL) circuitry adjusts the ratio of L-R back into proportion with the L+R and restores the octave-to-octave balance originally intended by the musician and recording engineer.

It does this by treating the L-R component of the digital disc differently than the L+R. Two equalization curves are necessary to make the disc sound like its analog counterpart. In addition to equalizing the two bands differently, the Digital Time Lens also restores the proper balance by increasing the L-R component back to realistic levels.

Since the equalization curves now differ, the Digital Time Lens corrects for the resulting time arrival difference by delaying the L+R signal. Then the two signals arrive at the next step in the cir-

cuity without time domain errors, yet with corrected equalization and proper L-R/L+R balance.

Which compact discs you choose to use the Digital Time Lens on will vary with your musical

tastes and systems. In most current discs, the improvement is noticeable. This unique circuit adds the finishing touches of sonic accuracy and realism, turning an innovation into near musical perfection.

thecarversite.com

7

Technical Information and Service Assistance

Troubleshooting Guide

Simple measure will correct most of the problems encountered in setting up and operating the TL-3300. If none of these solutions works for you, do not attempt to open or repair the TL-3300. Disconnect the unit's power and patch cords and contact your nearest Carver Service Station.

Problem	Probable Cause	Solution
The TL-3300 fails to turn on when the POWER button is pressed.	The power cord is loose.	Check to make sure the power plug is secure.
Playback does not begin.	The disc is upside down.	Reload the disc with the label side up.
	The disc is dirty.	Check the disc for excess dirt or foreign matter.
	Static discharge may have caused an error in the microprocessor.	Turn the unit off, then back on. If static discharge is a continuing problem, try lightly spraying the carpet around your stereo system with an antistatic spray. Do NOT spray the disc. The disc is encased in permanent antistatic plastic.
No sound.	Loose cables.	Check the output cables for proper connection.
	Preamp controls.	Verify that the preamplifier's controls are set properly.

Problem	Probable Cause	Solution
Sound skips.	Vibrations or physical shock.	Read the recommendation in Chapter 1 about correct placement of the TL-3300. Be sure you have removed the transport screws. (See page 10.)
	Bad disc.	Check the disc for dirt or deep scratches.
The "DISC" indicator lights, but the disc doesn't play.	Bad disc.	The compact disc is not providing lead-in information. Check for disc damage. Try another disc that you know works. Return and/or replace the disc as necessary.

WARNING: This compact disc player contains a laser system and is classified as a Class 1 laser product. To prevent direct exposure to the laser beam, do not try to open the enclosure for servicing or repair.

Radio and Television Interference

This equipment generates and uses radio frequency energy and if not installed and used properly, that is, in strict accordance with the manufacturer's instructions, may cause interference to radio and television reception.

The Compact Disc Player has been type tested and found to comply with the limits for a Class B computing device in accordance with the specifications in Subpart J of Part 15 of FCC rules, which are designed to provide reasonable protection against such interference in a residential installation. However, there is no guarantee that interference will not occur in a particular installation.

If this equipment does cause interference to radio or television reception, which can be determined by turning the equipment off and on, the user is encouraged to try to correct the interference by one or more of the following measures:

- Reorient the receiving antenna
- Relocate the Compact Disc Player with respect to the receiver
- Move the Compact Disc Player away from the receiver
- Plug the Compact Disc Player into a different outlet so that the Compact Disc

Player and receiver are on different branch circuits.

If necessary, the user should consult the dealer or an experienced radio/television technician for additional suggestions. The user may find the following booklet prepared by the Federal Communications Communications helpful:

How to Identify and Resolve Radio-TV Interference Problems

This booklet is available from the U.S. Government Printing Office, Washington, DC 20404, Stock No. 004-000-00345-4.

Handling Compact Discs

NOTE: The Carver Compact Disc Player has been designed specifically for reproduction of compact discs bearing this label:



No other discs can be played.

The Carver Compact Disc Player TL-3300 uses unusually sophisticated tracking and error correction circuits which will read discs virtually unplayable on some Compact Disc Players. Still, the discs should not be abused or handled carelessly.

While playback is not impaired by small dust particles or slight scratches, larger imperfections can prevent the player from tracking the disc. These mistrackings can cause the player to skip ahead or emit a small burst of high frequency noise.

To ensure long life for your discs, follow these guidelines:

- 1 Handling.** Grasp the disc by its edges only. Or, put a finger in the center hole and use your thumb to hold the disc steady.
- 2 Storing.** Return compact discs to their cases after use to avoid serious scratches which can occur from stacking them, sliding them on rough surfaces or leaving them out in direct sunlight.
- 3 Cleaning.** Wipe the surface of the disc with a soft cloth, either dry or moistened with water. Do not use conventional record cleaning products, antistatic sprays or alcohol. Wipe using straight motions from center to outside, as if you were tracing the spokes of a wheel.

Specifications

Frequency Response:	5 Hz - 20 kHz at 0 dB \pm 0.2 dB
Total Harmonic Distortion:	0.002% at 1 kHz
Signal-to-Noise Ratio:	100 dB
Channel Separation:	90 dB at 1 kHz
Dynamic Range:	100 dB
Wow and Flutter:	Unmeasurable
Output Voltage:	2.0 V (F.S.)
Power Consumption:	AC 120 V, 0.14 A

Service Assistance

NOTE: Fill out and mail the WARRANTY REGISTRATION CARD which is enclosed in a separate envelope with the CARVER LIMITED WARRANTY.

If your CARVER product should require service, we suggest you contact the Dealer from whom you purchased your unit. Should the Dealer be unable to take care of your needs, you may contact

CARVER Customer Service Department by phoning (206) 775-6245, or by writing CARVER CORPORATION, Customer Service Department, P.O. Box 1237, Lynnwood, WA 98046. We will then direct you to one of our national network of factory trained and authorized Warranty Service Centers, or give you detailed instructions on returning the product to us for prompt appropriate action.

We suggest you read the LIMITED WARRANTY completely to fully understand what your warranty/service coverage is, and the duration.

You must promptly complete and return the WARRANTY REGISTRATION CARD to validate your LIMITED WARRANTY.

We wish you many hours of musical enjoyment. If you should have questions or comments, please write to:

CARVER CORPORATION
Customer Service Department
P.O. Box 1237
Lynnwood, WA 98046
(206) 775-6245

Ask your CARVER Dealer to show you the CARVER family of stereo components for your home audio reproduction. Selected CARVER electronics that can accompany your TL-3300 are:

Preamplifier
Tuner
Speakers
Amplifier
CT-Seven Preamp/Tuner
Receivers

thecarversite.com



CARVER CORPORATION, P.O. Box 1237, Lynnwood, WA 98046

Printed in Japan
OM-844A 8904